



d sine

## Moulded Case Circuit Breakers



**LARSEN & TOUBRO**

It's all about Imagineering

## About us

---

Larsen & Toubro is a technology-driven USD 8.5 billion company that infuses engineering with imagination. The Company offers a wide range of advanced solutions in the field of Engineering, Construction, Electrical & Automation, Machinery and Information Technology.

L&T Switchgear, which forms part of the Electrical & Automation business, is India's largest manufacturer of low voltage switchgear, with the scale, sophistication and range to meet global benchmarks. With over four decades of experience in this field, the Company today enjoys a leadership position in the Indian market with growing presence in international markets.

It offers a complete range of products including controlgear, powergear, motor starters, energy meters, wires and host of other accessories. Most of our product lines conform to international standards, carry CE marking and are **KEMA** certified.

The **d sine** range, a new generation of MCCBs, stands out due to its state-of-the-art design, contemporary user-friendly features, wide choice of protective releases, ergonomics, aesthetics and compactness.

The **d sine** range complies with the latest standards like IEC 60947-2, EN 60947-2 & IS 13947-2. The products conform to international standards, carry CE markings and are **KEMA** & CB certified. The range is specially designed for tropical conditions, ensuring reliable performance at high ambient and humid environments.

The **d sine** range is designed to meet the changing needs of users after extensive analysis and user feedback. The range can satisfy the most demanding system requirements.

The **d sine** range, complimented by a wide range of accessories, offer total solution to customer applications ensuring operational safety, reliability and versatility.



Switchgear Factory, Mumbai

Range .....	1
Protection Releases .....	2
Salient Features .....	5
Accessories .....	7
Widest Range .....	11
Time-Current Characteristics .....	12
Overall Dimensions .....	15



DN4

DN3

DN2

## Features

- ➔ From 63 A to 1250 A
- ➔ 3 Pole & 4 Pole
- ➔ Choice of 36kA/50kA/70kA breaking capacities
- ➔ With protection releases in Microprocessor, Thermal-Magnetic and only Magnetic
- ➔ MCCBs for distribution and SD versions
- ➔ Manual, rotary or motorised versions
- ➔ Wide range of internal and external accessories

DN2		
Rated Current	63, 80, 100, 125, 160, 200, 250 A	40, 63, 100, 160, 250 A
Release	Thermal-Magnetic	Microprocessor
DN3		
Rated Current	320, 400, 500, 630 A	63, 160, 250, 400, 630 A
Release	Thermal-Magnetic	Microprocessor
DN4		
Rated Current	800, 1000, 1250 A	
Release	Microprocessor	

## Breaking Capacities

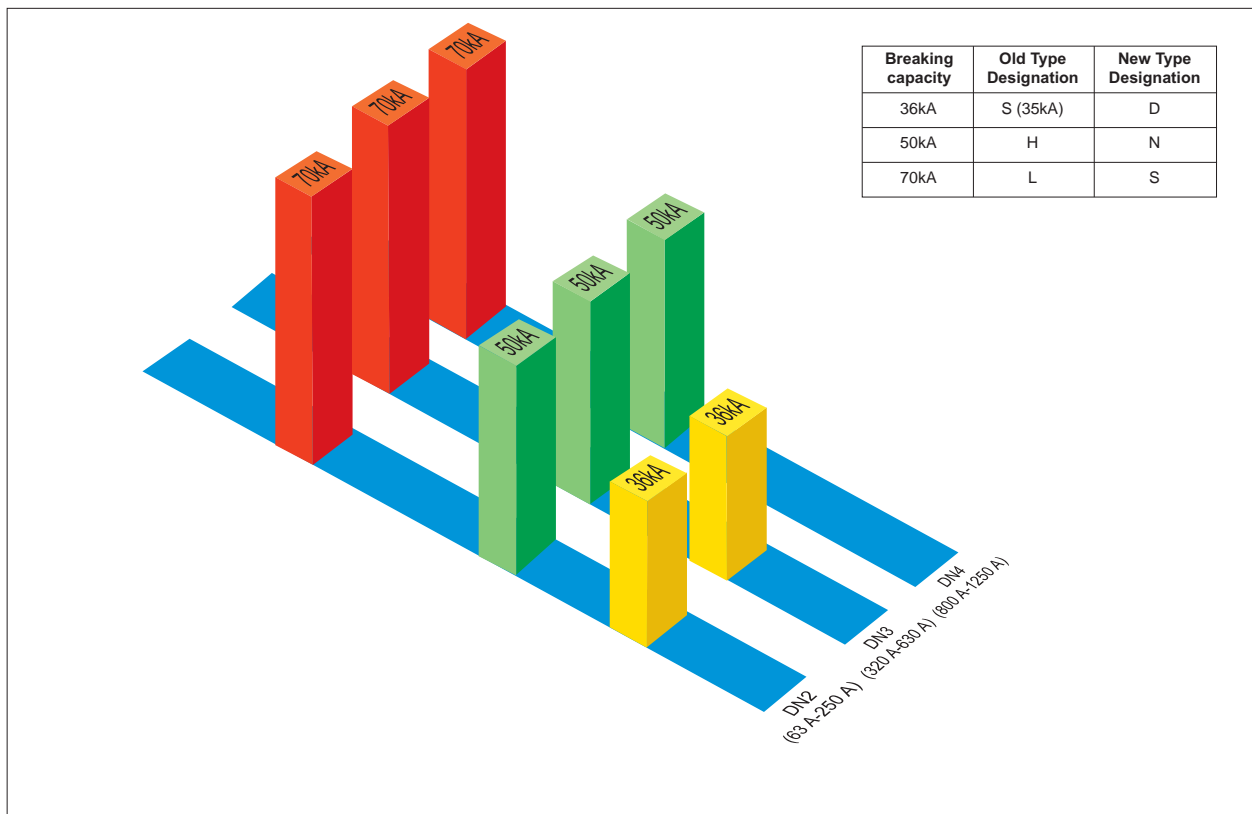

Note : Since there is no change in the constructional aspect of the MCCBs, the product certification with old designation remain valid with new type designation.

### Thermal-Magnetic Release



#### Features of Thermal-Magnetic Release

- Adjustable overload settings
- Adjustable short circuit settings
- True RMS sensing
- No contact with live parts

Protection	Settings
	DN2 & DN3
Overload	80% - 100% $I_n$
Short circuit*	6 - 10 $I_n^*$
Earth fault	External

\*Except for 630A MCCBs. Setting from 3 - 6  $I_n$  available on request.

### Microprocessor Release

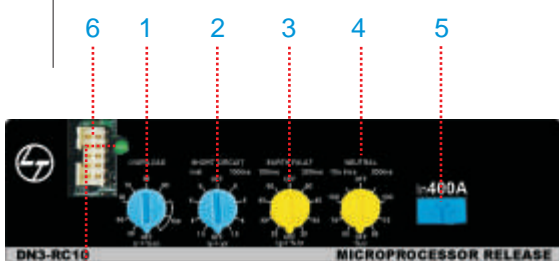

#### Features of RC10 Microprocessor Release

- Overload protection with inverse time delay ①
- Short circuit protection with selectable time delay ②
- Instantaneous over ride protection
- Earth fault protection with selectable time delay ③
- Neutral protection with selectable time delay ④
- Push to trip button ⑤
- Port for release testing ⑥
- Power ON LED ⑦
- Self powered protections
- True RMS sensing

RC10	
Rated Current $I_n$ (A)	From 63 to 1250 A
Overload (Phase)	
Current setting, $I_r$ ( $I_r = X I_n$ )	OFF, 0.4 to 1.0 in steps of 0.1
Time delay, $t_r$ (Inverse)	10 sec at $6 I_r$
Protection mode	ON / OFF
Overload (Neutral)	
Current setting, $I_n$ ( $I_{nrl} = X I_n$ )	0.5, 0.75 & 1.00 $I_{nrl}$
	Inverse 10 sec at 6 $I_{nrl}$ / Fixed 200ms
Protection mode	ON / OFF
Short Circuit	
Current setting, $I_s$ ( $I_s = X I_r$ )	1.5, 4 & $6 I_r$
Time delay, $t_s$	Inst. / 100 msec
Protection mode	ON / OFF
Instantaneous Over ride	
Current setting, $I_p$	DN2-8 $I_n$ , DN3-400-12 $I_n$ , DN3-630-8 $I_n$ , DN4-8 $I_n$
Earth Fault	
Current setting, $I_g$	0.2 to 0.5 $I_n$ steps of 0.1
Time delay, $t_g$	100 / 200 msec
Protection mode	ON / OFF

## Microprocessor Release



### Features of RC20 - Communication Capable

- Communication using RS 485
- Power on LED
- Backlit LCD display
- Scroll buttons
- Push to trip button
- All features of RC10 release are incorporated
- Metering for current parameters
- Protection against unbalanced load / single phasing
- $I^2t$  protection
- Neutral protection
- Cold load protection
- User friendly navigation system
- Self powered
- MODBUS RTU protocol

RC20	
Rated Current $I_n$ (A)	From 63 to 630 A
Overload (Phase)	
Current setting (A), $I_r$ ( $I_r = xI_n$ )	0.4 to 1.0 in steps of 0.1
Time delay, $t_r$ (s) (Inverse)	3, 6, 10, 15, 30 at $6I_r$
Protection mode	ON / OFF
Preset trip alarm setting	0.8 to $1.0I_r$ in steps of 0.05
Thermal memory	ON / OFF
Overload (Neutral)	
Current setting (A), $I_r$	50%, 100% $I_n$
Protection mode	ON / OFF
Short Circuit	
Current setting (A), $I_s$	1.5, 4, $6I_r$
Time delay $t_s$ (ms)	For – $I^2t$ OFF 20 to 200 in steps of 20
	For – $I^2t$ ON 60 to 200 in steps of 20
Protection mode	ON / OFF
Preset trip alarm setting	0.8 to 1.0 times $I_s$ in steps of 0.05 $I_s$
Cold load pickup	Enable / Disable
Instantaneous	
Instantaneous	1.5 to $8I_n$ in steps of $0.5I_n$
Protection mode	ON / OFF
Cold load pickup	Enable / Disable
Instantaneous Over ride	
Current setting (A), $I_p$	DN2- $8I_n$ , DN3-400- $12I_n$ , DN3-630- $8I_n$ , DN4- $8I_n$
Earth Fault	
Current setting (A), $I_g$	0.2 to $0.5I_n$ steps of $0.1I_n$
Time delay (ms), $t_g$	0.1, 0.2, 0.5, 1, 3 sec.
Preset trip alarm setting	0.8 to 1.0 $I_g$ in steps of 0.05
Protection mode	ON / OFF
Cold load pickup	Enable / Disable

## Additional Features of RC20

Current unbalance	
Current setting (A) $xI_n$	10% to 100% $I_n$ in steps of 5%
Time delay (s)	1 to 10 in steps of 0.5
Protection mode	ON / OFF
Cold load pickup	Enable / Disable
Temperature rise	
Alarm / Trip	At 80°C / At 100°C
Metering	
Current	Phase, Neutral and Earth
Display	Backlit LCD
Communication*	
Protocol	MODBUS RTU
Link used	RS 485
Event records	Pickup, Trip, Alarm upto 128 records-volatile memory
Trip history	Last 5 trips records - non volatile memory
Trip counter record	Counts for total number of trips

\* To establish communication with computer every MCCB with RC20 will require a communication module.

→ **Faster tripping**

The unique speed contact system accelerates the opening of contacts during short circuit. This ensures faster tripping an ultimate current limiting feature. The result-very low let-through, cut-off current and fault clearing time.

→ **Mechanical Anti-reclosing**

This unique feature ensures that under short circuit conditions, the contacts open and latch even before the release gives a trip command to the mechanism. This avoids contact re-closing and bounce.

→ **Low watt loss**

The entire current carrying path is optimally designed to achieve very low watt loss.

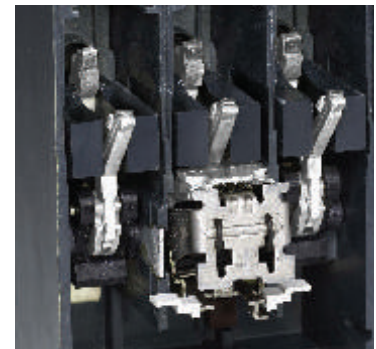

→ **Positive Isolation**

The MCCB knob indicates the true position of the contacts.

→ **Double Insulation**

The internal accessories are housed in insulated casings to ensure first level of insulation. When the front cover is opened for the fixing of internal accessories, the MCCB is totally insulated ensuring the double insulation.

→ **Marking**

CE marking ensures use of superior engineering plastic, meeting all requirements of flammability and glow wire testing path is optimally designed to achieve very low watt loss.

- ➔ **Common Internal accessories**  
The internal accessories remain same across DN2 / DN3 / DN4 range\* and they are snap fit type easy to install

- ➔ **No load line bias**  
Either side of MCCB terminal can be used as load or line

- ➔ **Terminal finger proofing**  
Front terminal plates conceal the terminals to prevent human contact thus achieving complete finger proofing
- ➔ **Release shrouding**  
Release is shrouded from the front thus preventing tampering by unauthorized person
- ➔ **Safer release adjustments**  
No live parts are in contact during release adjustments

- ➔ **Common front adjustments for protection release**  
Overload & short circuit setting can be adjusted from front using a common knob for all the poles
- ➔ **Visibility**  
Push to trip button and release ratings are visible even when release plate is fitted

\* Except under voltage release

**Internal Accessories**



**Auxiliary Contact**

**d sine** range of MCCBs come with snap-fit type, easily installable internal accessories. There is no need to open main cover and no live parts are accessed during installation. TAC, Aux+TAC to be fitted in the right cavity & under voltage release to be fitted in left cavity.

**List of Internal Accessories**

- ➔ Auxiliary Contact 1 C/O
- ➔ Auxiliary Contact 2 C/O
- ➔ Trip Alarm Contact
- ➔ Auxiliary & Trip Alarm Contact
- ➔ Shunt Release
- ➔ Under Voltage Release (suitable for electrical interlocking)



**MCCB with mid cover opened & Internal accessories fitted**

**External Accessories**

**Extended Rotary Handle (Panel Mounted)**

- ➔ ROM mounts directly on the MCCB without removal of mid cover
- ➔ Clear ON / OFF / TRIP indication
- ➔ Clear view of the MCCB rating label with ROM mounted
- ➔ Direct access to push to trip button with ROM mounted
- ➔ IP 54 degree of protection with extended rotary handle
- ➔ Unique coupling to allow  $\pm 3\text{mm}$  tolerance
- ➔ Door interlock in ON position, with defeat facility
- ➔ Door interlock in OFF condition with padlock feature
- ➔ Auto restoration of door interlock
- ➔ External keylock for mechanical interlocking



**Extended Rotary Handle:  
Panel Mounted**



**Panel Door Mounted Key lock**  
(To be used along with extended rotary handles)



**Rotary Operating Mechanism**

The rotary operating mechanism (ROM) for **d sine** MCCBs are available in Direct & Extended versions.

**Direct rotary handle (MCCB mounted)**

These versions are available for the entire family of **d sine** MCCBs.

### Mechanical Interlocking Schemes

#### 1. Mechanical Interlocking Kit:

Two MCCBs can be interlocked using base plate mechanism, in side-by-side configuration.

##### Features

- ➔ For 3 Pole & 4 Pole versions
- ➔ For DN2 & DN3 frames
- ➔ Site fittable



#### 2. Mechanical Interlocking using key locks:

For mechanical interlocking through extended rotary operating mechanism, a panel mounted key lock is available. The selection of the key lock as per the following details:

2 I/C	Any 1 type of lock for both MCCBs
2 I/C and 1 B/C	Lock 1 and Lock 2 for I/C and Lock 12 for B/C
3 I/C and 2 B/C	Locks 1, 2, 3 for I/Cs and Locks 12, 23 for B/Cs

### Key Lock Selection

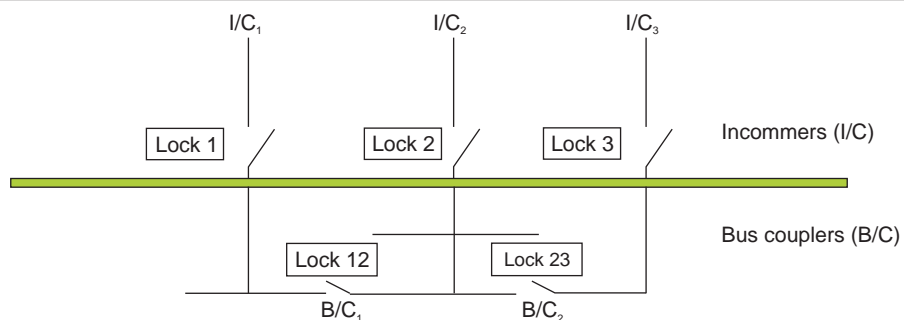

Type of lock	Exclusively operable by Key Nos.
1	1
2	2
3	3
12	1, 2 & 12
23	2, 3 & 23

## Electrical Operating Mechanism



### Features

- ➔ Clear **ON / OFF** indication
- ➔ Safety Interlock-EOM will not operate if
  - EOM cover is open
  - EOM is not properly fixed on MCCB
- ➔ Permits manual operation, If required
- ➔ Padlock facility for locking in OFF position
- ➔ Easy access to the protection setting on the MCCBs

\* 240 VAC available on request

## External Neutral CTs

The External Neutral CT is an add-on accessory of the 3P MCCB that gives protection against neutral faults. Thus, with an External Neutral CT, a 3P MCCB can be used for full protection of a 3 phase, 4 Wire system\*.

\* Contact nearest branch for details & availability

### Automatic Source Transfer Switch Controller AuXC-1000

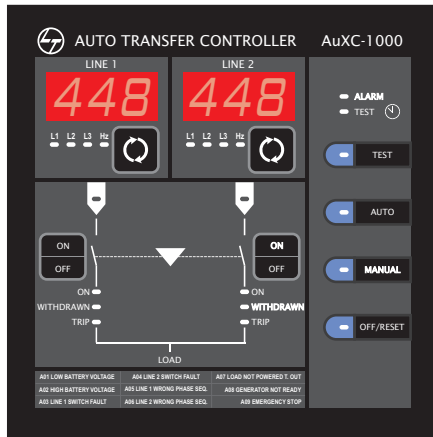

The AuXC-1000 controller brings simplicity and flexibility to an auto source transfer system. It has been developed to control and supervise the automatic or manual transfer of a utility load from a principal power supply source to a stand-by. It sets a new benchmark in Auto source transfer switch controller technology.

It includes all the necessary features to supervise and control power supply sources, composed by energy distribution systems or generating sets, and the relative transfer equipment, such as contactors, motorized moulded case circuit breakers and air circuit breakers.

**The automatic transfer takes place through AuXC-1000 whenever conditions predefined by the user takes place, for example:**

- Power supply source not respecting programmed limits
- The need to have a very reliable power source
- The need to use the most economical power source

**Some of the key features of this controller are:**

- Front display for monitoring the system voltage and frequency and for onsite controller programming
- Six programmable inputs and five programmable outputs
- Front test feature to simulate the operation of the diesel generator set
- Status indication through 22 LEDs
- Flush mounting arrangement
- Communication capable

The AuXC-1000 controller is compatible with U-Power range of Air circuit breakers, [d sine](#) range of MCCBs and MCX range of contactors.



MIL with Base Plate & EOM

# Technical Data



Frame		250 A			400 A			630 A			800 / 1000 / 1250 A		
Type		DN2-250			DN3-400			DN3-630			DN4-1250		
		D	N	S	D	N	S	D	N	S	N	S	
Current Range (A)		63, 100, 125, 160, 200 & 250 A			63, 160, 250, 320, 400			63, 160, 250, 320, 400, 630 A			800, 1000, 1250		
Poles		3 / 4			3 / 4			3 / 4			3 / 4		
Impulse withstand Voltage (kV)		8			8			8			8		
Rated Operational Voltage (V) (max)		690			690			690			690		
Rated Insulation Voltage (V)		750			750			750			750		
Utilisation Category		A			A			A			A		
Standard		IEC / EN / IS / GB			IEC / EN / IS / GB			IEC / EN / IS / GB			IEC / EN / IS / GB		
IEC-60947-2	Icu (kA)	230 / 240 V	65	85	100	65	85	100	65	85	100	85	100
		400 / 415 V	36	50	70	36	50	70	36	50	70	50	70
		500 V	25	36	50	25	36	50	25	36	50	25	36
		550 V	18	25	36	15	20	25	15	20	25	20	25
		600 V	16	18	22	12	18	22	12	18	22	16	20
		690 V	10	15	20	8	15	20	8	10	15	10	18
		250 V DC (3P in series)	15	25	36	15	25	36	15	25	36	-	-
	500 V DC (3P in series) L/ R<15msec	5	10	20	5	10	20	5	10	16	-	-	
Ics as % Icu		100%	100%	100%	100%	100%	100%	100%	100%	100%	100%	100%	
Life span		Mechanical	25000			15000			15000			8000	
		Electrical @1.0 In	10000			4000			2000			750	
Operating Frequency (Hz)		50 / 60			50 / 60			50 / 60			50 / 60		
Total Opening Time		<10 msec			<10 msec			<10 msec			<20 msec		
Finger-proof Terminals		Yes			Yes			Yes			Yes		
Ambient Temperature		-5° to 55° C			-5° to 55° C			-5° to 55° C			-5° to 55° C		
Storage Temperature		-35° to 70° C			-35° to 70° C			-35° to 70° C			-35° to 70° C		
Mounting Positions		Vertical and 90° in both directions			Vertical and 90° in both directions			Vertical and 90° in both directions			Vertical and 90° in both directions		
Dimensions (W x D x H)		3-Pole	105 x 96 x 179			140 x 111.5 x 266			140 x 111.5 x 266			278 x 143 x 370	
		4-Pole	140 x 96 x 179			183.5 x 111.5 x 266			183.5 x 111.5 x 266			278 x 143 x 370	
Weight (kg) (3/4 Pole)		2.5 / 3.3			5.5 / 7.2			6 / 7.8			15 / 16		
ACCESSORIES	Internal	Auxiliary Contact	1C/O or 2C/O			1C/O or 2C/O			1C/O or 2C/O			1C/O or 2C/O	
		Trip Alarm Contact	1C/O			1C/O			1C/O			1C/O	
		Auxiliary & Trip Alarm Contact	1C/O + 1C/O			1C/O + 1C/O			1C/O + 1C/O			1C/O+1C/O	
		Shunt Release \$	110 - 415 V AC 50 / 60 Hz, 110 - 220 V DC			110 - 415 V AC 50 / 60 Hz, 110 - 220 V DC			110 - 415 V AC 50 / 60 Hz, 110 - 220 V DC			110 - 415 V AC 50 / 60 Hz, 110 - 220 V DC	
	Under Voltage Release	220 - 240 V AC 50 Hz			220 - 240 V AC 50 Hz			220 - 240 V AC 50 Hz			220 - 240 V AC 50 Hz		
	Rotary Operating Mechanism	✓			✓			✓			✓		
	Electrical Operating Mechanism	✓			✓			✓			x		
	External	Earth Fault Release	✓			Inbuilt protection with Microprocessor release			Inbuilt protection with Microprocessor release			Inbuilt protection with Microprocessor release	
	Mechanical Interlock	✓			✓			✓			✓		
	Spreader Links	✓			✓			✓			✓		
	Key lock / Pad lock	✓			✓			✓			✓		

\$ : 'NO' of control contactor to be connected in series for 220V DC application.  
 Note: • Any two internal accessories can be mounted at a time  
 • For special application like capacitor switching, DC please contact nearest branch office  
 • For motor application, use 'M' series MCCBs (DN2M, DN3M)

## Thermal-Magnetic Release

### DN0-100

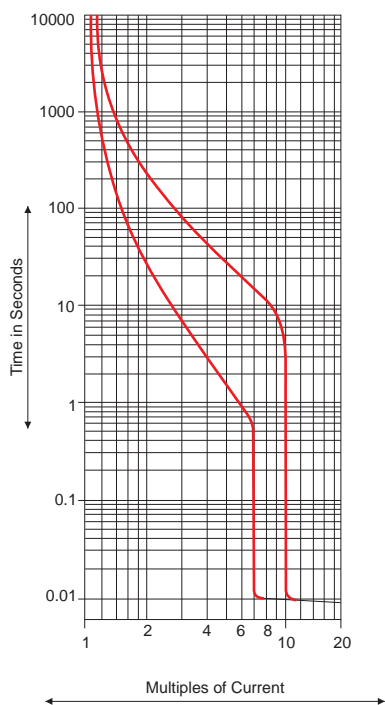

### DN2-160/250

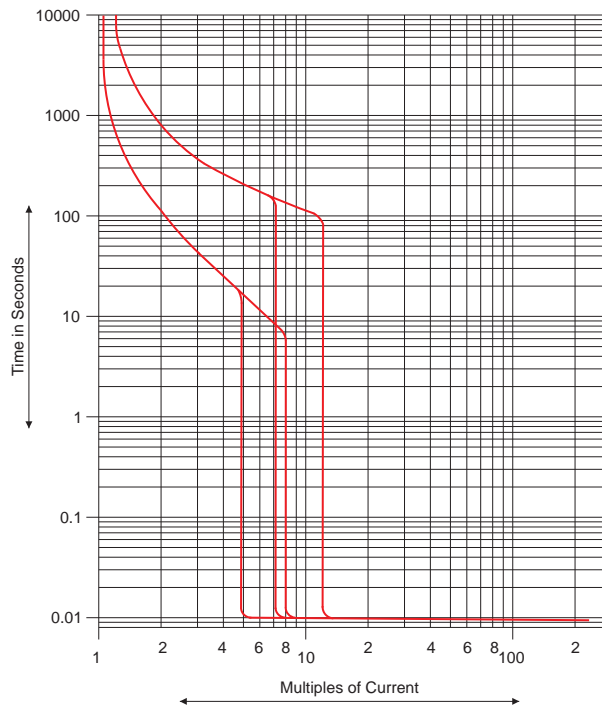

### DN3-400/630

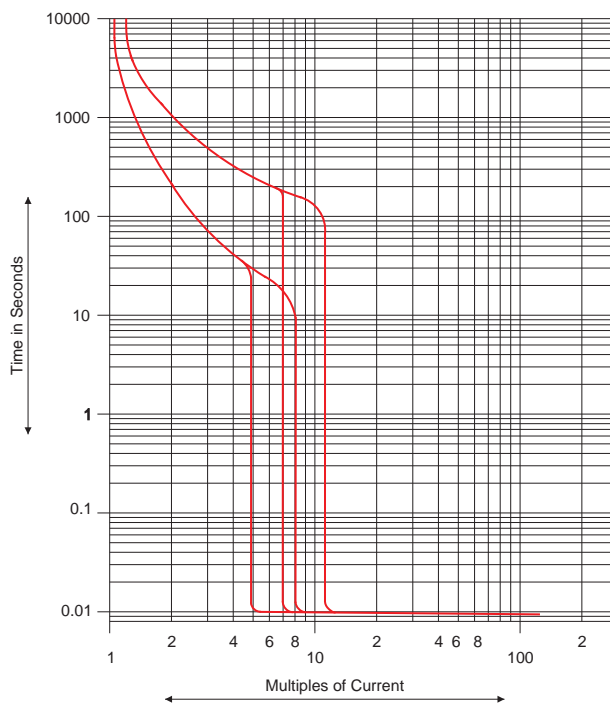

## Microprocessor Release-RC10

### DN2-250A

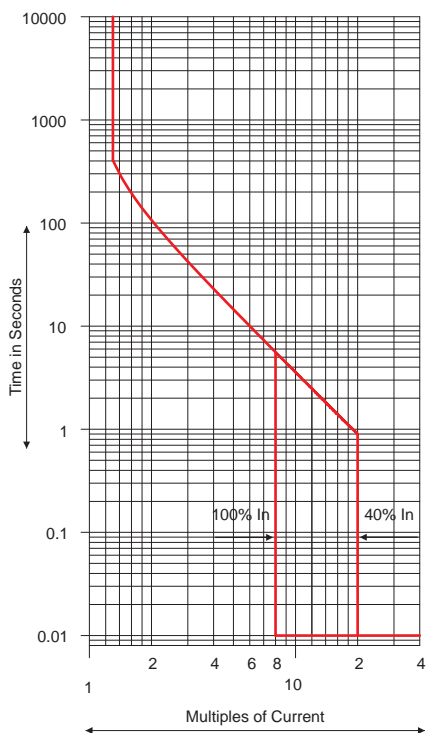

### DN3-400A

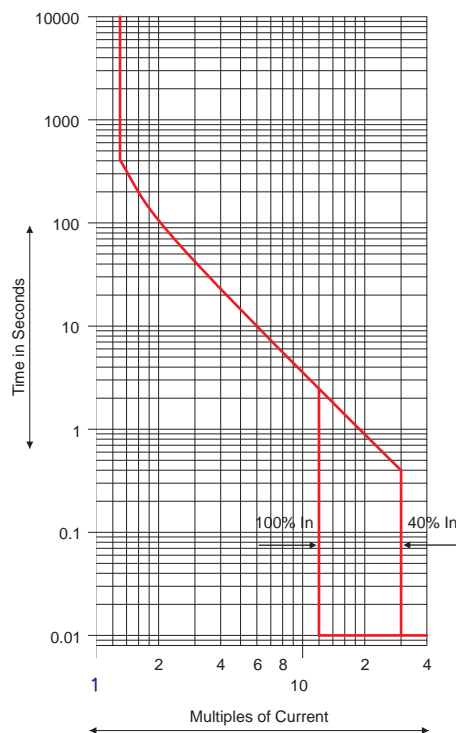

### DN3-630A

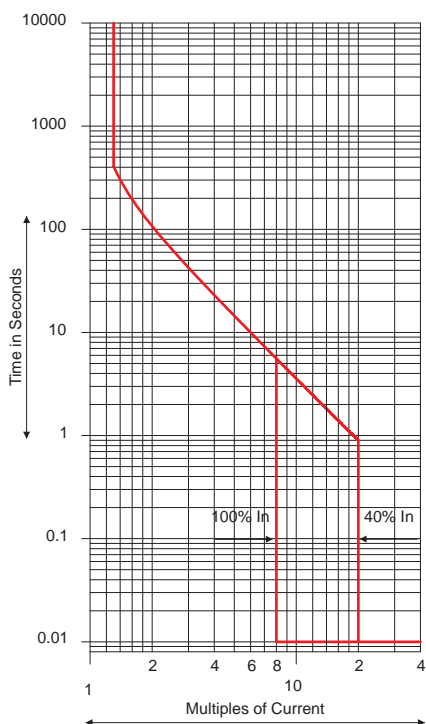

### DN4-1250A

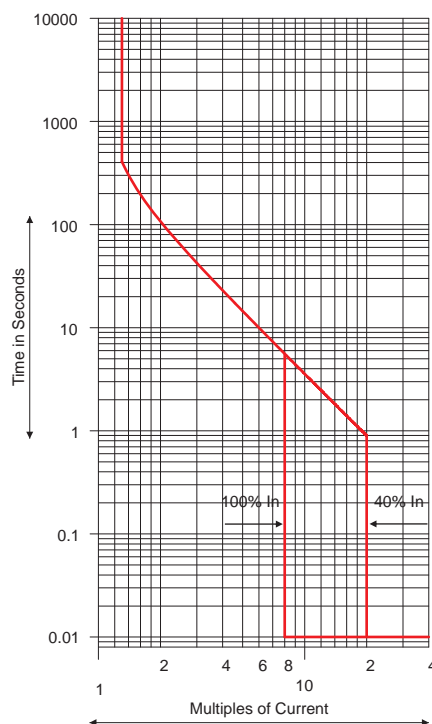

## Microprocessor Release-RC20

### DN2-250A

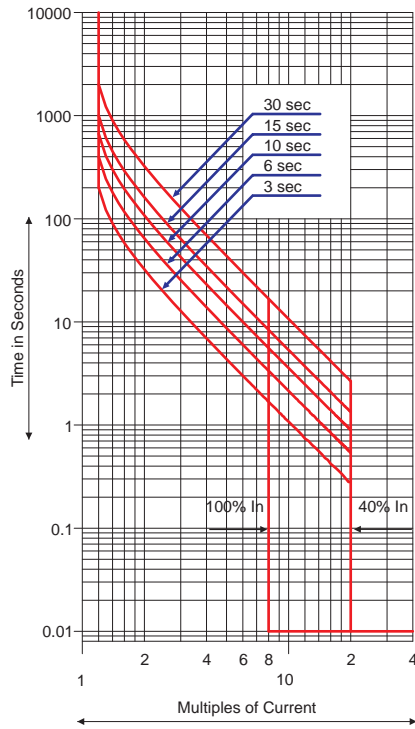

### DN3-400A

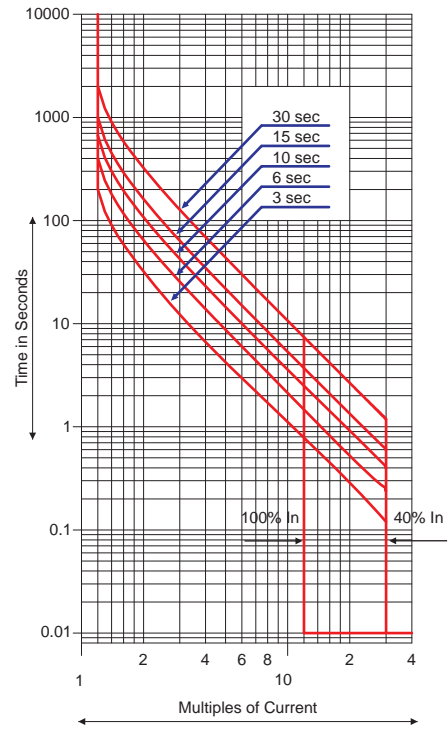

### DN3-630A

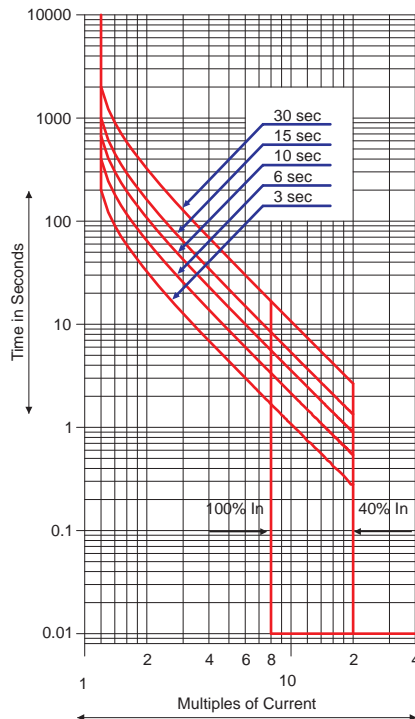

### DN4-1250A

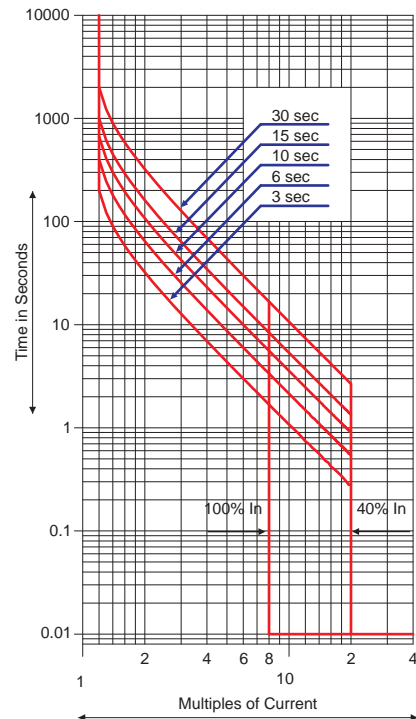

## DN2-250 MCCB

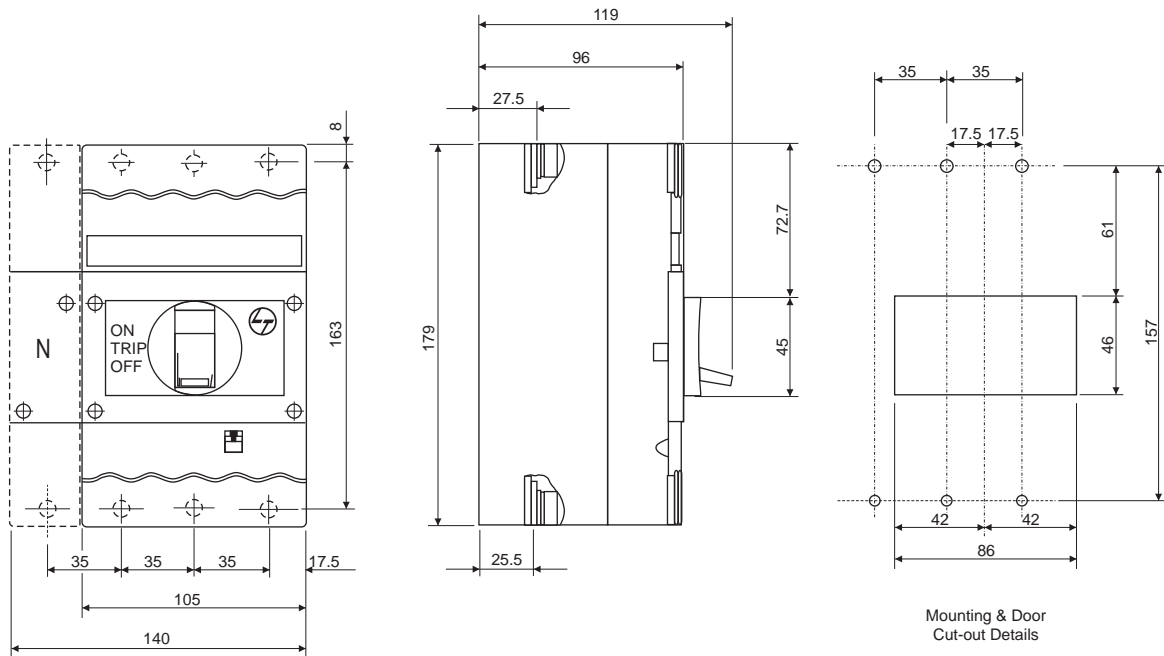

Terminal width = 25.5mm

## DN2-250 3P with Spreader Links

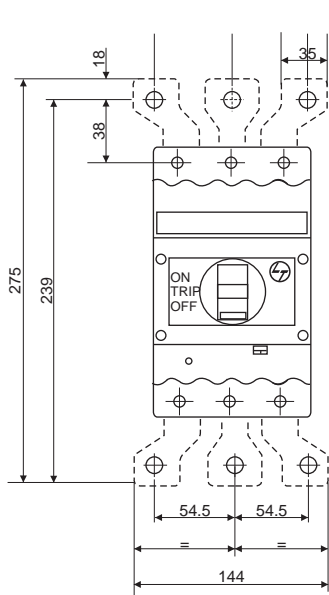

## DN2-250 4P with Spreader Links

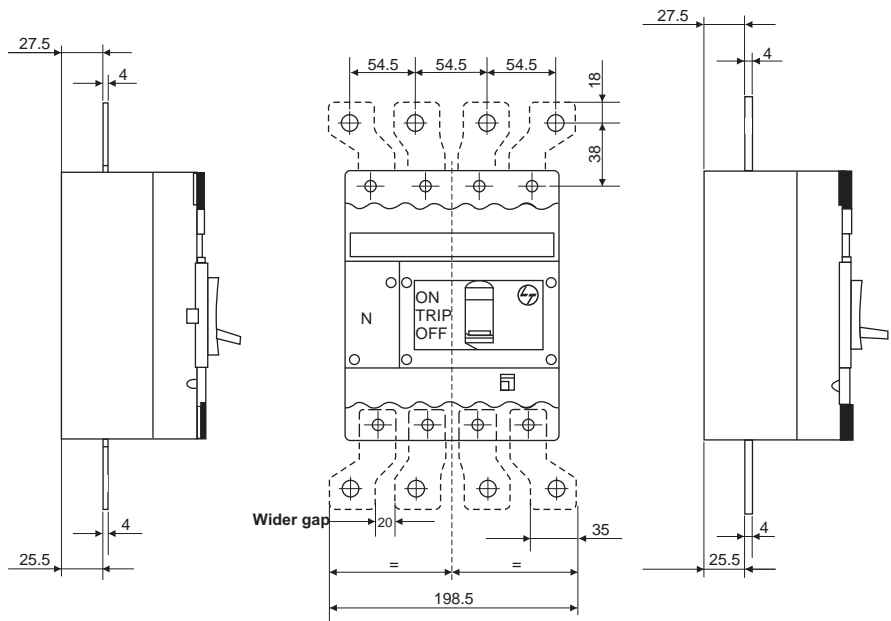

Recommended CAT number for DN2 spreaders

3P	4P
ST980530000	CM920070000

Note : Spreader links are available as spare. It is recommended to use spreader links for enhancing termination capacity.

All dimension are in mm

**DN3-400/630 MCCB**

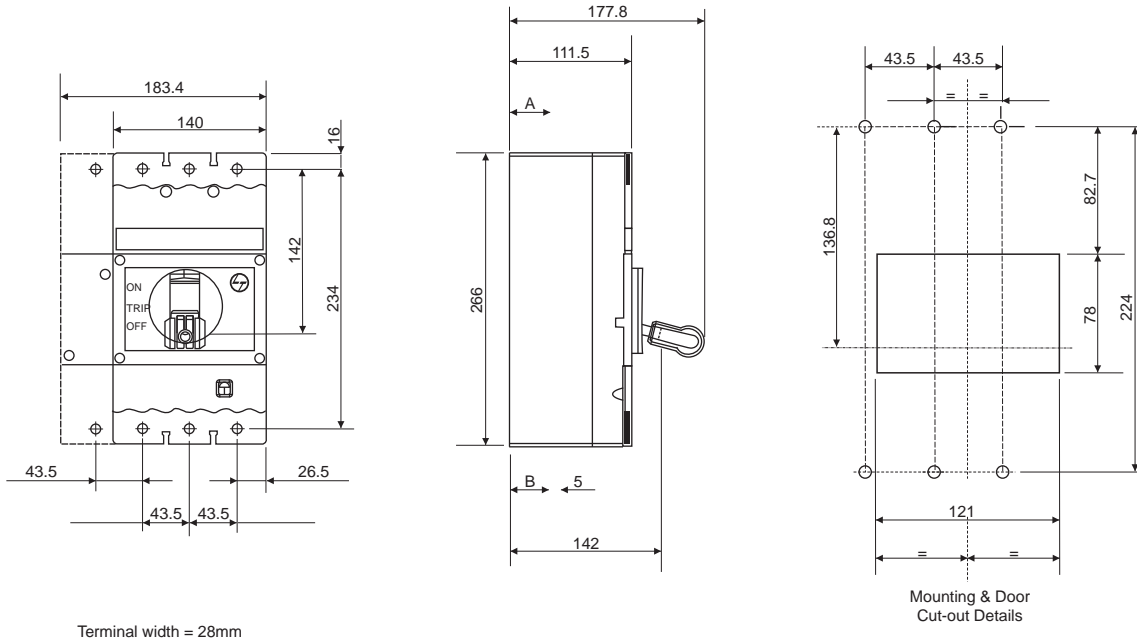

**DN3-400/630 3P with Spreader Links**

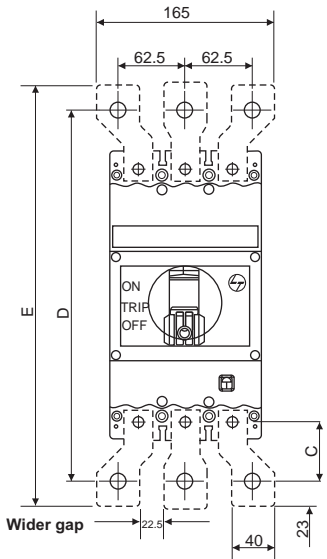

**DN3-400/630 4P with Spreader Links**

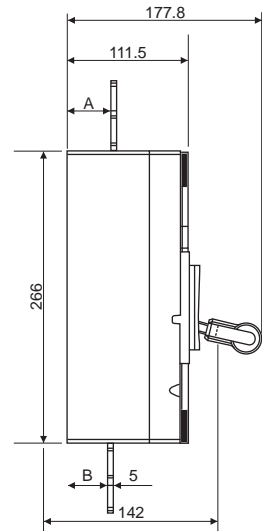
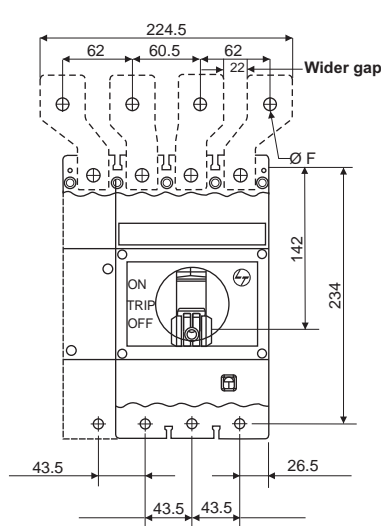

Type	DN3-400	DN3-630
A	39	41
B	37	38
C	45	55
D	324	344
E	370	390
F	13	11

Recommended CAT numbers for DN3 spreaders

Rating	3P	4P
400A	ST980650000	ST980660000
630A	ST980540000	CM920040000

Note : Spreader links are available as spare. It is recommended to use spreader links for enhancing termination capacity.

All dimension are in mm

## DN4-800/1000/1250 MCCB

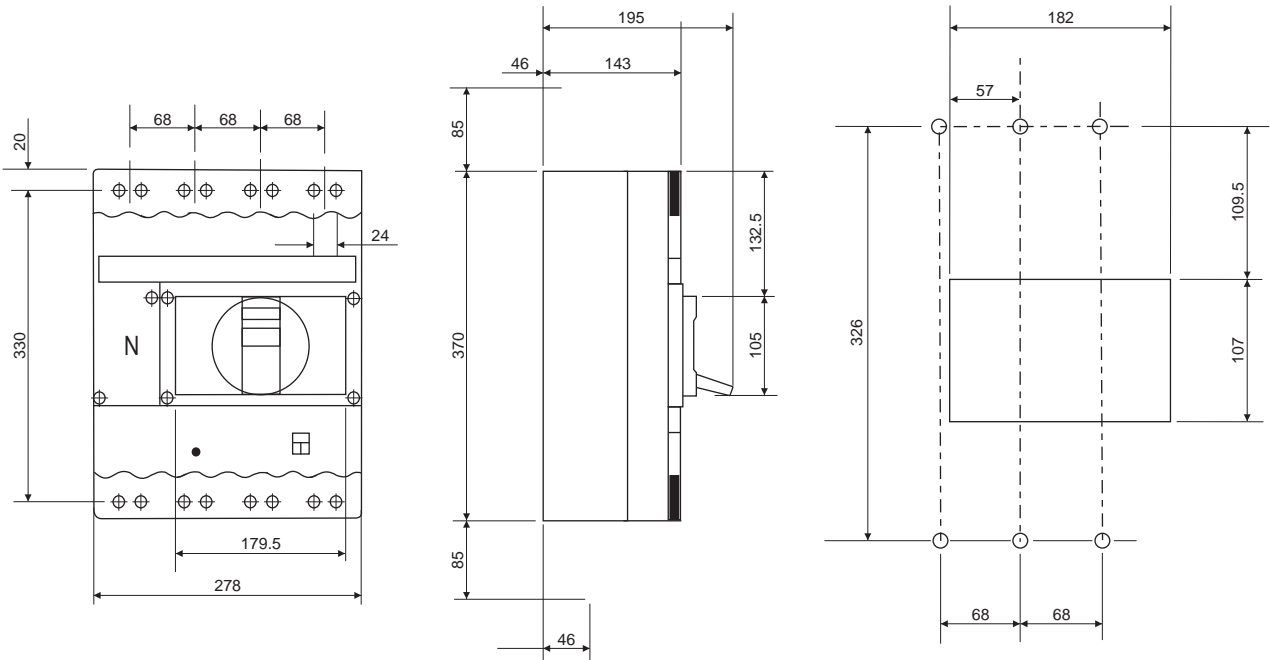

## DN4-800 MCCB with Spreader Links

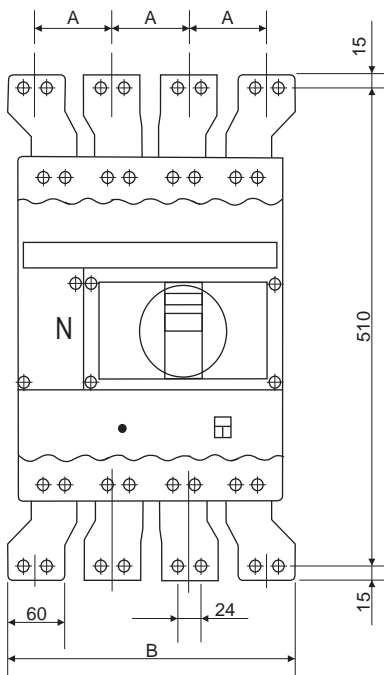

## DN4-1000/1250 MCCB with Spreader Links

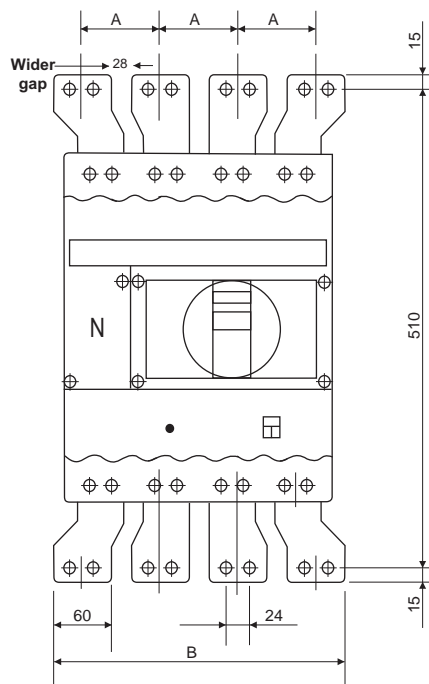

## DN4-800/1000/1250 MCCB

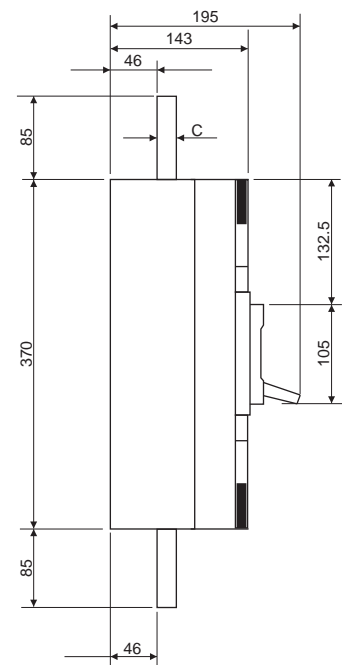

Dimensions

Type	A	B	C
800A	88	324	6
1000/1250/1600A	80	300	20

Recommended CAT numbers for DN4 spreaders

Rating	3P	4P
800A	ST90361O000	ST90362O000
1000A /1250A	ST98055O000	ST98058O000

Note : Spreader links are available as spare. It is recommended to use spreader links for enhancing termination capacity.

All dimension are in mm

## Direct ROM door cut-out detail

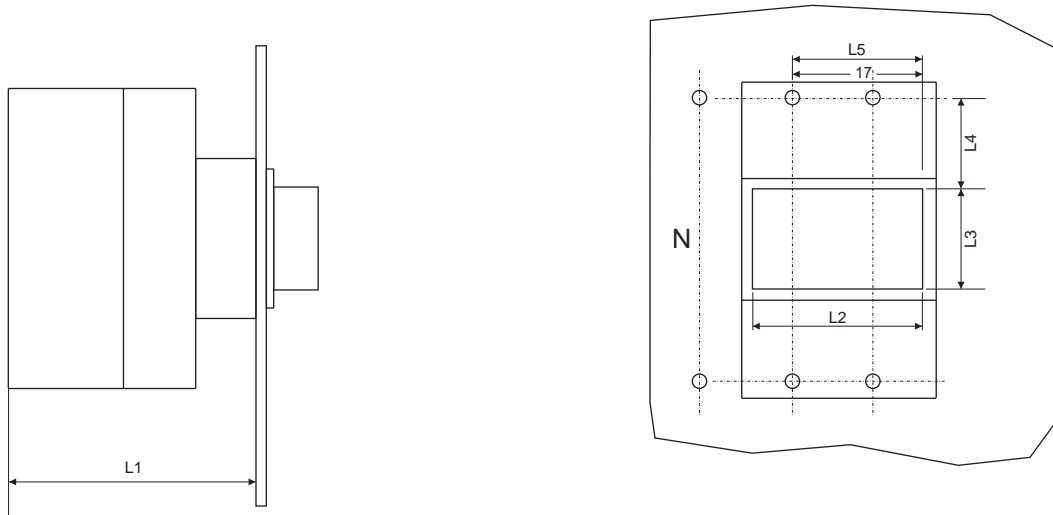

L1 = Mounting depth  
 L2/L3 = Panel cut-out  
 L4/L5 = Breaker mounting reference

Type	L1	L2	L3	L4	L5
DN0	96.5	58	52	44	37
DN2	122	96	63	53	66
DN3	156	121	87	78	82

## Extended ROM door cut-out detail

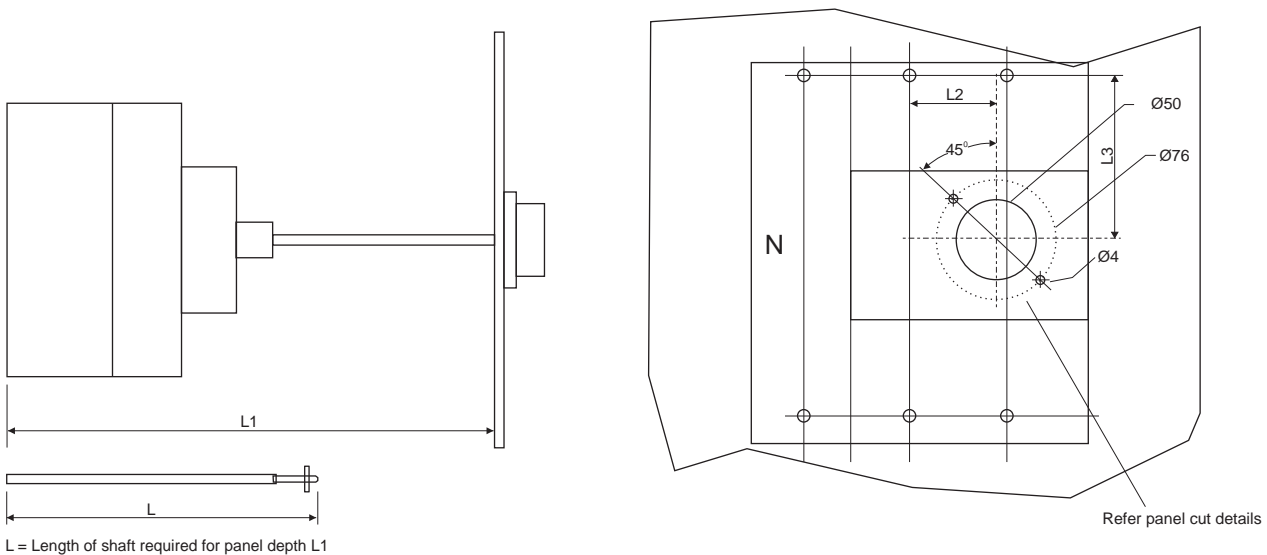

L = Length of shaft required for panel depth L1

Type	L1	L	L2	L3
DN0	169	L1 - 119	7.5	69.5
DN2	202	L1 - 152	27	84
DN3	233	L1 - 183	39	122
DN4	302	L1 - 252	69	170

All dimension are in mm

## MCCB with EOM

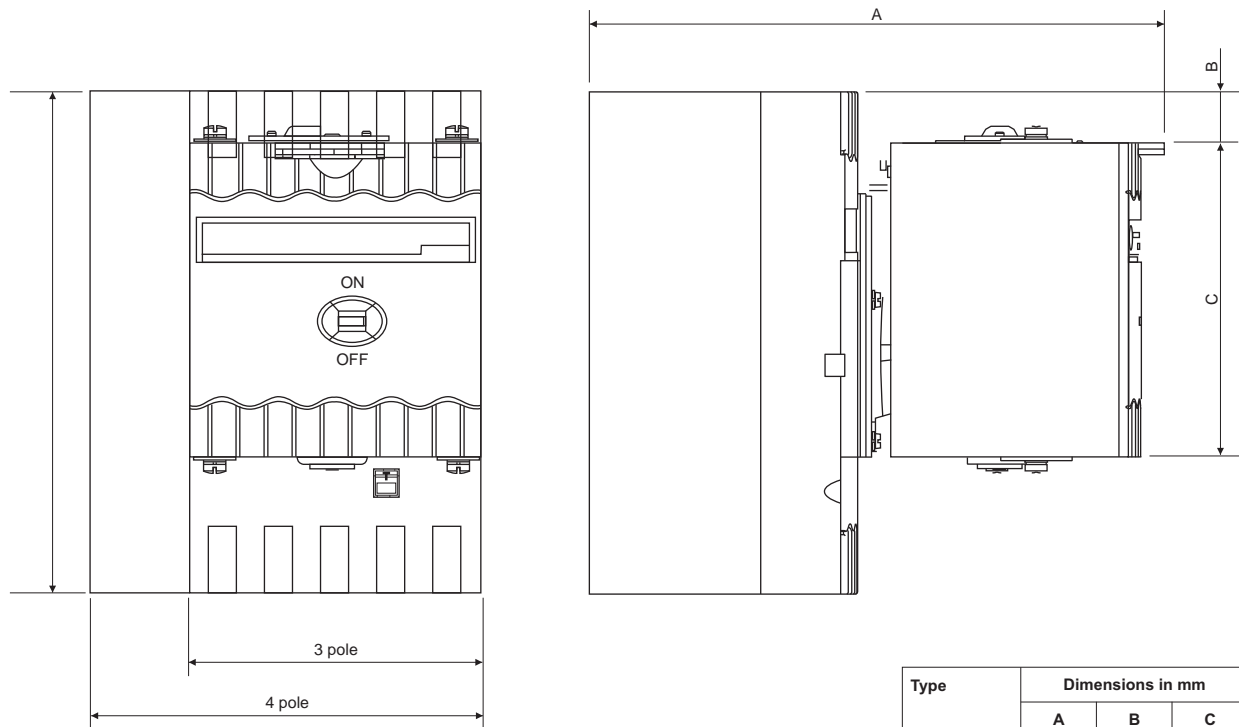

Type	Dimensions in mm		
	A	B	C
For DN2 EOM	205	18	112.3
For DN3 EOM	226	46.5	147.3

## Panel Mounted Key Lock

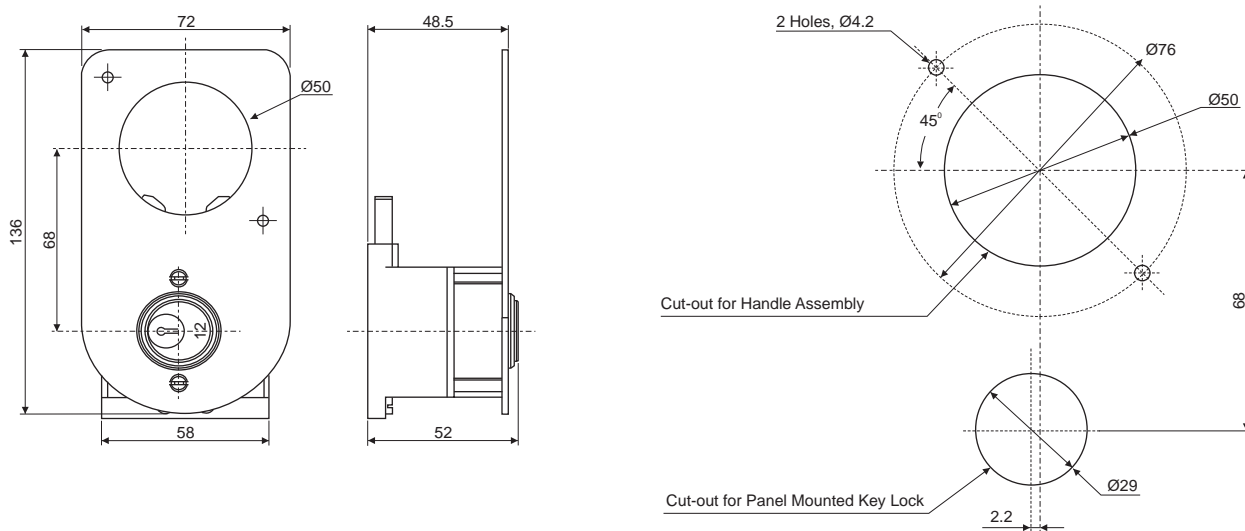

All dimension are in mm

DN2 MIL Kit

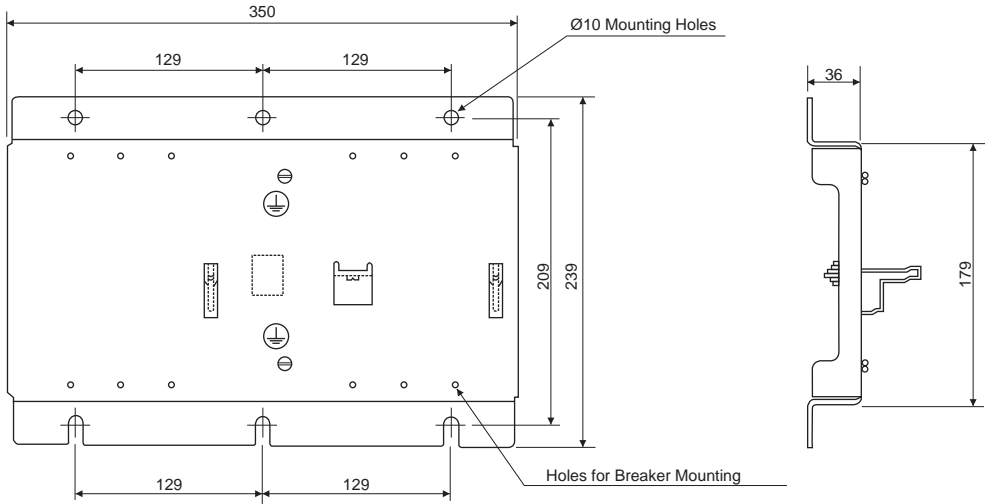

DN3 MIL Kit

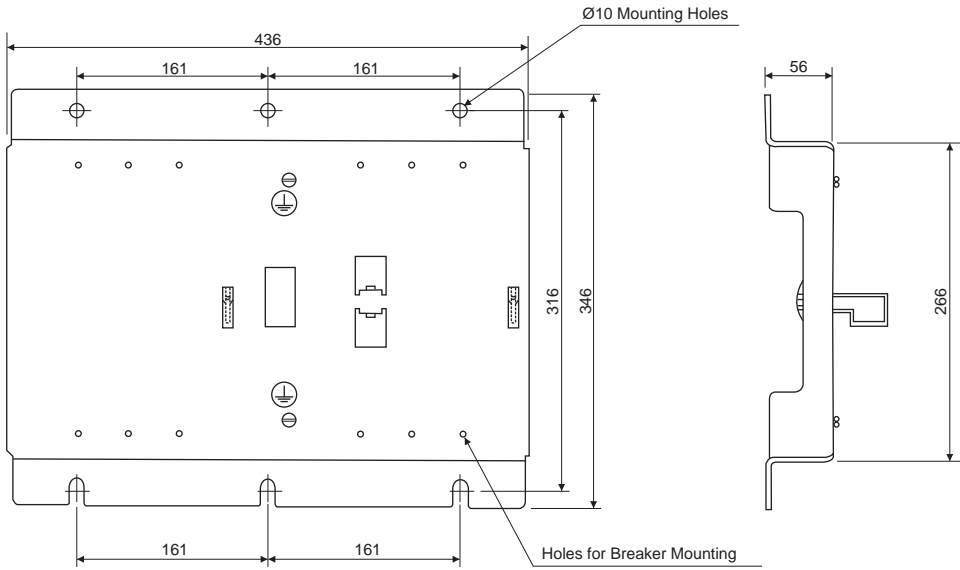

All dimension are in mm

## External Neutral CTs

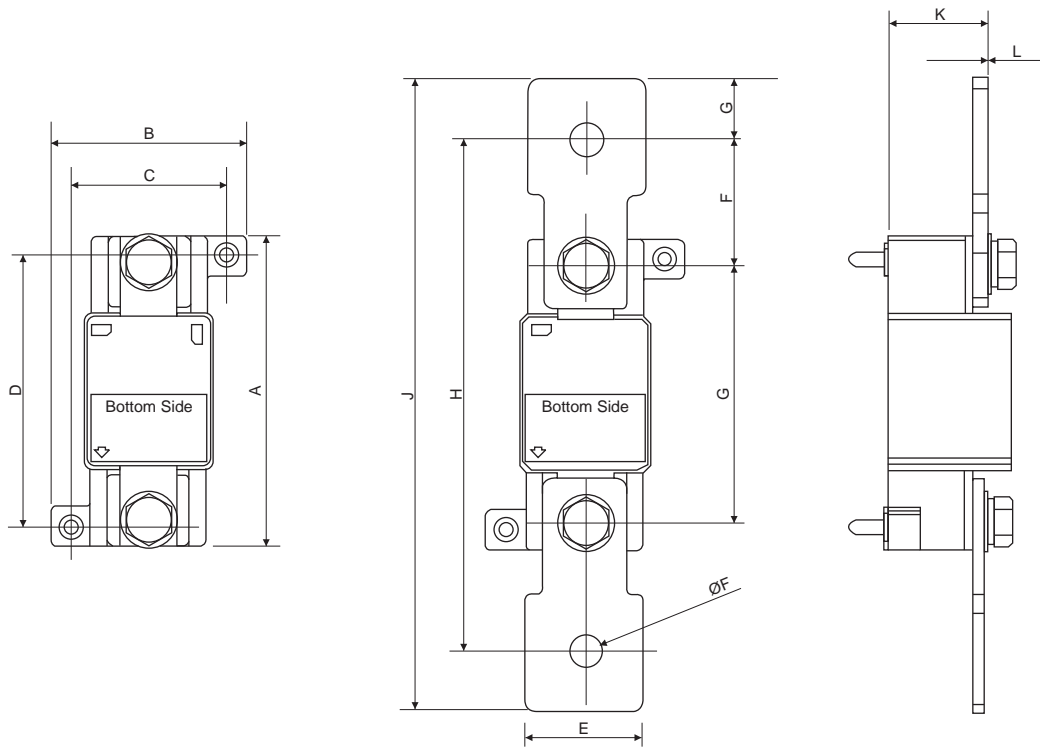

	A	B	C	D	E	F	G
DN2 250A	93	59	47	81	35	10.2	77
DN3 400A	93.5	58	46	81.5	40	13	63.5
DN3 630A	93.5	58	46	81.5	40	10.5	63.5

	H	J	K	L	M
DN2 250A	153	189	26	4	55
DN3 400A	153.5	199.5	39	5	60
DN 630A	173.5	219.5	39	5	60

**Note:** Adaptor Terminals shown are not available with product. kindly refer accessories data for ordering separately. Circuit Breaker shown for reference only.

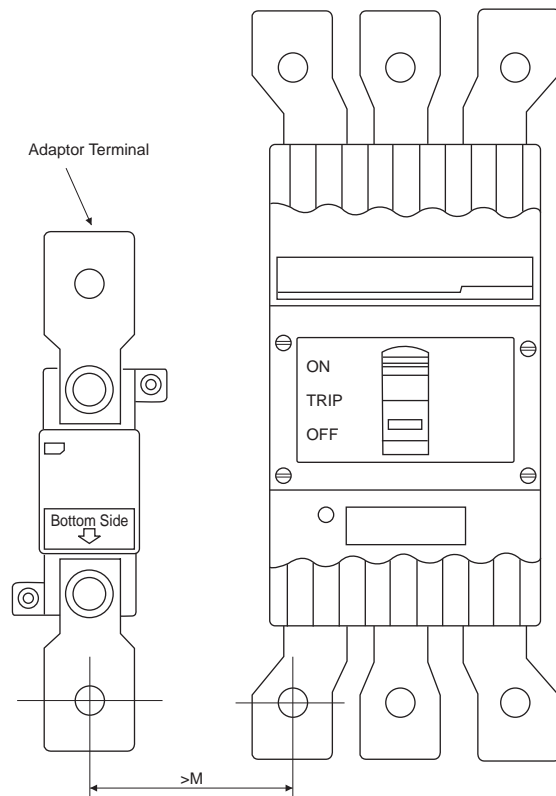

All dimension are in mm

External Neutral CTs

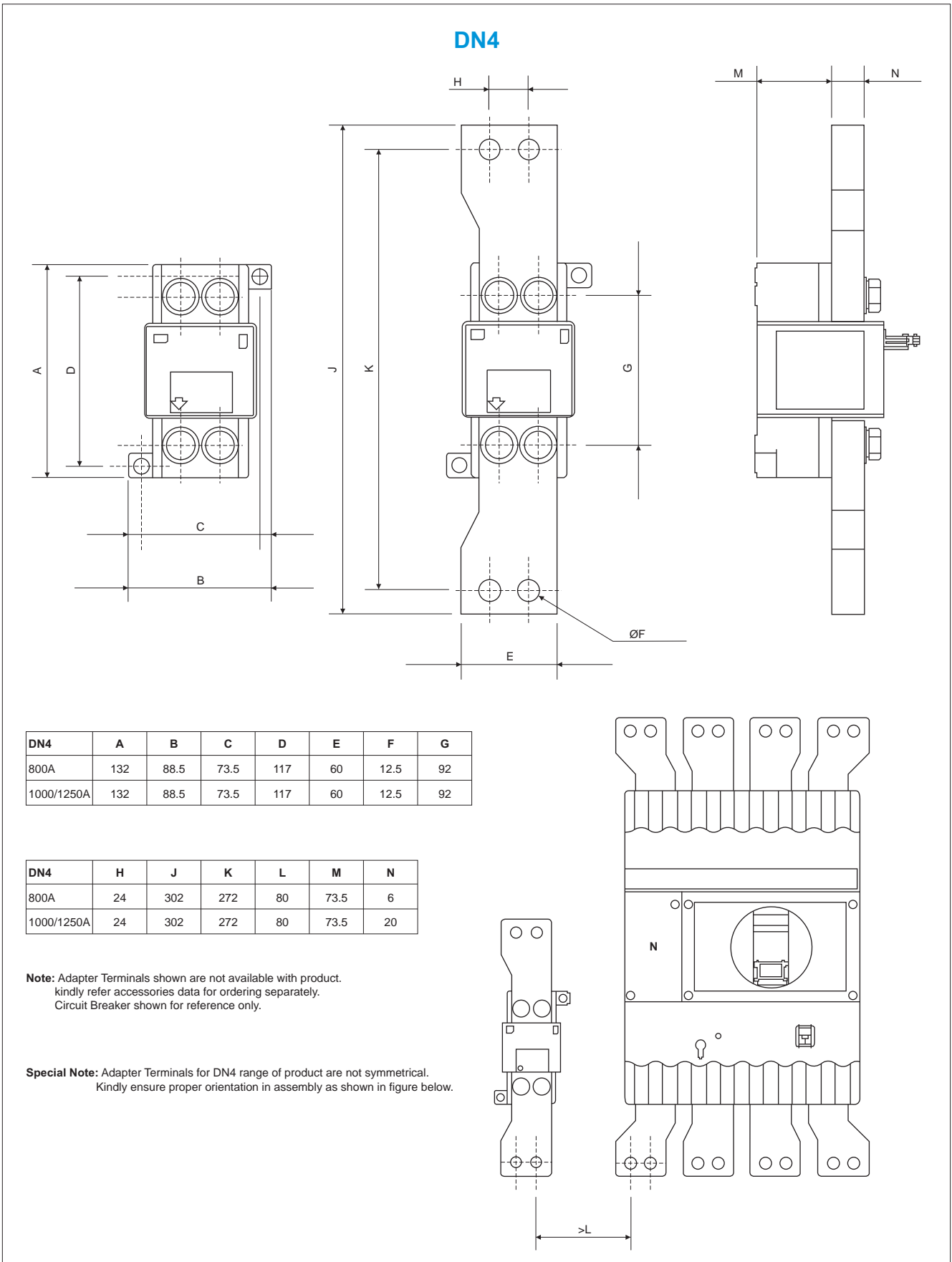

DN4	A	B	C	D	E	F	G
800A	132	88.5	73.5	117	60	12.5	92
1000/1250A	132	88.5	73.5	117	60	12.5	92

DN4	H	J	K	L	M	N
800A	24	302	272	80	73.5	6
1000/1250A	24	302	272	80	73.5	20

**Note:** Adapter Terminals shown are not available with product. kindly refer accessories data for ordering separately. Circuit Breaker shown for reference only.

**Special Note:** Adapter Terminals for DN4 range of product are not symmetrical. Kindly ensure proper orientation in assembly as shown in figure below.