

SUPERNOVA™

Motor Protection Circuit Breakers



About us

Larsen & Toubro is a technology-driven USD 9.8 billion company that infuses engineering with imagination. The Company offers a wide range of advanced solutions in the field of Engineering, Construction, Electrical & Automation, Machinery and Information Technology.

L&T Switchgear, which forms part of the Electrical & Automation business, is India's largest manufacturer of low voltage switchgear, with the scale, sophistication and range to meet global benchmarks. With over four decades of experience in this field, the Company today enjoys a leadership position in the Indian market with growing presence in international markets.

It offers a complete range of products including controlgear, powergear, motor starters, energy meters, wires and host of other accessories. Most of our product lines conform to international standards, carry CE markings and are *KEMA*  certified.



Switchgear Factory, Mumbai

SUPERNOVA™ Product Range

L&T introduces complete range of Supernova products covering Motor Protection Circuit Breakers, Contactors / Thermal Overload Relays & Motors.

Motor Protection Circuit Breakers

The new range of MPCBs is meant for protection against short circuit & overload.



MO Contactors & RTO Thermal Overload Relays



The latest range of Contactors & Thermal Overload Relays, rated from 9A to 110A.

Motors



L&T offers higher efficiency 3 phase LT motors, synonymous with ruggedness and reliability, suitable for all industrial applications upto 400 kW.

Motor Protection Circuit Breakers



Functions

Moulded Case Circuit Breaker and Thermal Overload Relay functions integrated into a highly compact unit known as Motor Protection Circuit Breaker.

Circuit Breaker Functions

- Short circuit protection
- Overcurrent protection
- Line protection

Thermal Overload Relay Functions

- Overload protection
- Phase loss protection
- Rated current adjustment
- Ambient temperature compensation

MPCB - Advantages

- Compactness
- High Breaking Capacity
- Short circuit protective coordination
- Reduction in wiring work
- Ecological design standards

Selecting the Appropriate Model

Procedure for selecting the appropriate model:

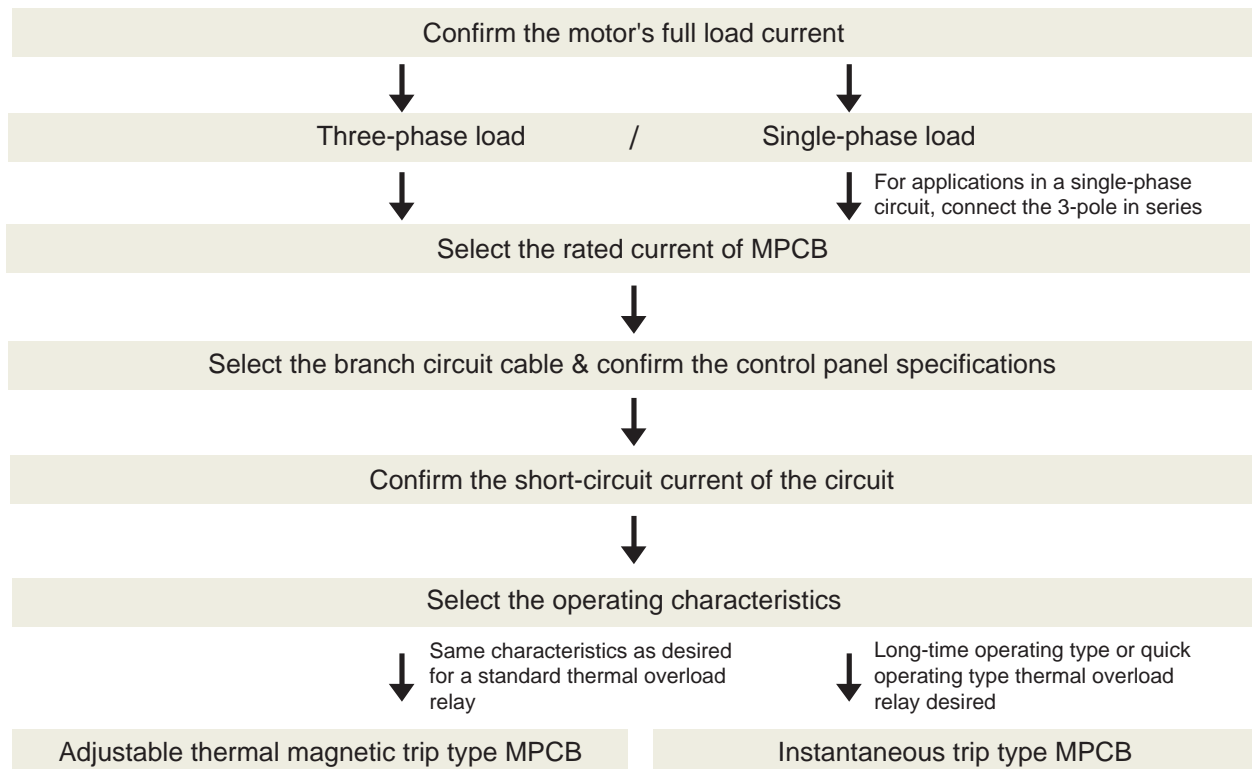

Typical Problem in the Conventional System and their Solution by using MPCB

Short-Circuit Breaking Capacity

When numerous small and medium motor loads exist in a circuit requiring high breaking capacity, there is no high breaking capacity circuit breaker with a small rated current for a short circuit protection.

The MPCB can be used in 100kA short circuit current circuits for three-phase, 240V motors with rated capacity upto 15kW, and in 50kA short circuit current circuits for three phase, 415V motors with rated capacity up to 30kW.

Back-up breaking system

When back-up MCCB is installed upstream to solve the problem described in “ Short-circuit breaking protection ” above, a short in one of the load circuits also trips the upstream breaker and stops the other operating circuits.

Despite their compact size, the MPCB provides high-performance short-circuit current breaking. They eliminate the need for an upstream circuit breaker for back-up use.

Overload Protection

Motor Protection breakers cannot be adjusted to match the rated current of the motor being protected.

Equipped with a wide range current adjustment dial (with maximum/minimum ratio of 1.4 to 1.6), the MPCB easily adjusts to match the rated current of the motor, for optimum protection.

Control Panel Size

Considerable space is required to install a back-up circuit breaker or a combination starter consisting of a circuit breaker and a thermal overload relay. As a result, the panel size has to be increased.

The compact size of the MPCB, including overload relay functions, enables a smaller installation area with less wiring space, for a reduction in panel size.

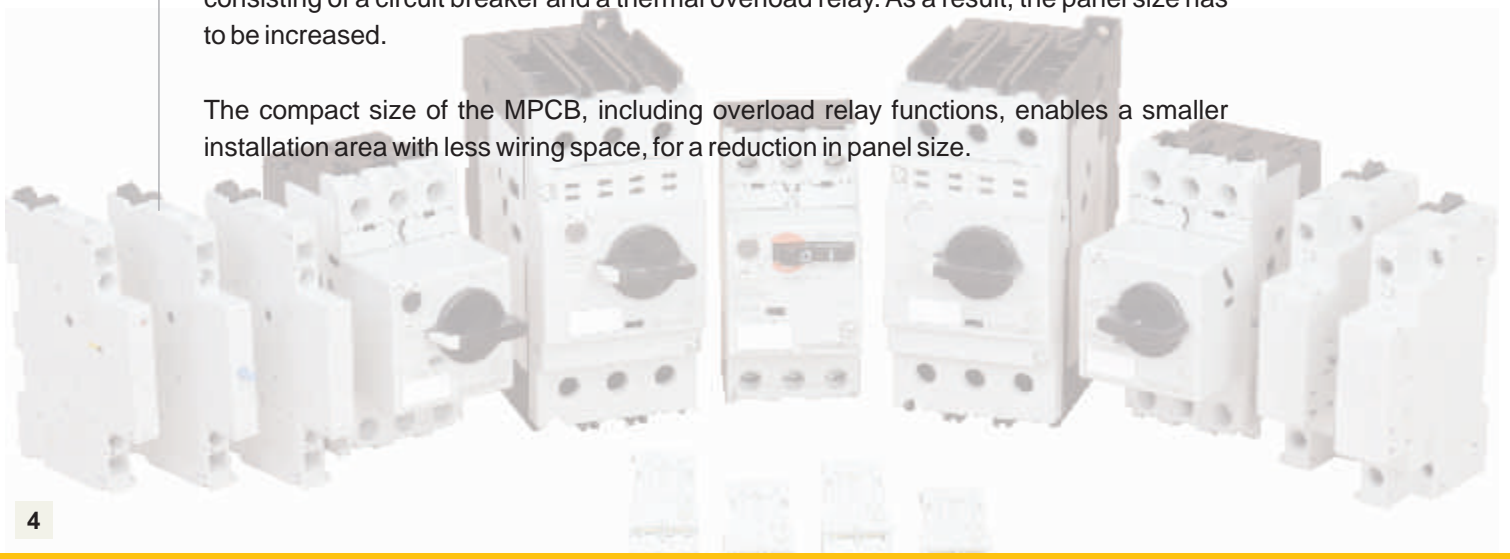

Technical Specifications



Type	MOG - S1		MOG - H1		MOG - H2		MOG - H1M		MOG - H2M		
Standards	IEC60947 -1, -2, -4 -1		IEC60947 -1, -2, -4 -1		IEC60947 -1, -2, -4 -1		IEC60947 -1, -2, -4 -1		IEC60947-1, -2, -4 -1		
Handle type	Rocker		Rotary		Rotary		Rotary		Rotary		
Number of poles	3		3		3		3		3		
Frame	13A		32A		63A		32A		63A		
Rated insulation voltage (Ui)	AC690V		AC690V		AC1000V		AC690V		AC1000V		
Rated operational voltage (Ue)	AC200 - 690V		AC200 - 690V		AC200 - 690V		AC200 - 690V		AC200 - 690V		
Rated impulse withstand voltage (Uimp)	6KV		6KV		8KV		6KV		8KV		
Rated frequency	AC50 / 60Hz		AC50 / 60Hz		AC50 / 60Hz		AC50 / 60Hz		AC50 / 60Hz		
Utilization Category (IEC947 - 4 - 1 / 947 - 2)	AC - 3 / Cat. A		AC - 3 / Cat. A		AC - 3 / Cat. A		AC - 3 / Cat. A		AC - 3 / Cat. A		
Maximum motor capacity AC3	7.5 kW (at 200 - 240V), 15 kW (at 380 - 440V)		7.5 kW (at 200 - 240V), 15 kW (at 380 - 440V)		15 kW (at 200 - 240V), 30 kW (at 380 - 440V)		7.5 kW (at 200 - 240V), 15 kW (at 380 - 440V)		15 kW (at 200 - 240V), 30 kW (at 380 - 440V)		
AC3 Electrical/Mechanical endurance	100000 (32A:70000) / 100000 (32A:70000), (25cycles / hour)		100000 (32A:70000) / 100000 (32A:70000), (25cycles / hour)		25000 / 50000, (25cycles / hour)		100000 (32A:70000) / 100000 (32A:70000), (25cycles / hour)		25000 / 50000, (25cycles / hour)		
Tripping device	Thermal - Magnetic		Thermal - Magnetic		Thermal - Magnetic		Magnetic		Magnetic		
Ambient temperature compensation	-20°C ~ + 60°C		-20°C ~ + 60°C		-20°C ~ + 60°C		-20°C ~ + 60°C		-20°C ~ + 60°C		
Overload, Phase loss protection	yes (according to IEC60947 - 4 - 1)		yes (according to IEC60947 - 4 - 1)		yes (according to IEC60947 - 4 - 1)		None		None		
Trip Indicator	Yes		Yes		Yes		Yes		Yes		
Test Trip Function	Yes		Yes		yes		Yes		Yes		
Instantaneous release	13 X Ie max.		13 x Ie max.		13 x Ie max.		13 x Ie max.		13 x Ie max.		
Terminal type	Screw terminal, M4 slotted		Screw terminal, M4 slotted		Box terminal, M6 slotted		Screw terminal, M4 slotted		Box terminal, M6 slotted		
Wire size	Solid/Stranded	1 - 10mm ² x 1 / 18 - 8 AWG x 1		1 - 10mm ² x 1 / 18 - 8 AWG x 1		1 - 25mm ² x 1 / 18 - 4 AWG x 1		1 - 10mm ² x 1 / 18 - 8 AWG x 1		1 - 25mm ² x 1 / 18 - 4 AWG x 1	
	Without/With end sleeve	1 - 6mm ² x 2 / 18 - 10 AWG x 2		1 - 6mm ² x 2 / 18 - 10 AWG x 2		1 - 16mm ² x 2 / 18 - 4 AWG x 2		1 - 6mm ² x 2 / 18 - 10 AWG x 2		1 - 16mm ² x 2 / 18 - 4 AWG x 2	
Product weight (Kg)	0.35		0.35		0.78		0.37		0.78		
Dimensions (mm) W x H x D	45 x 90 x 66		45 x 90 x 66		55 x 110 x 96		45 x 90 x 79		55 x 110 x 96		
Standard service condition	Relative humidity	45 ~ 85%RH	No dew formation or freezing due		45 ~ 85% RH	No dew formation or freezing due		45 ~ 85% RH	No dew formation or freezing due		
	Operation altitude	Up to 2000m	to rapid temperature change allowed		Up to 2000m	to rapid temperature change allowed		2000m	to rapid temperature change allowed		
	Atmosphere	Atmosphere having no excess Vapour, Steam, Dust, Corrosive gas, Salt, Flammable gas		Atmosphere having no excess Vapour, Steam, Dust, Corrosive gas, Salt, Flammable gas		Atmosphere having no excess Vapour, Steam, Dust, Corrosive gas, Salt, Flammable gas		Atmosphere having no excess Vapour, Steam, Dust, Corrosive gas, Salt, Flammable gas		Atmosphere having no excess Vapour, Steam, Dust, Corrosive gas, Salt, Flammable gas	

Breaking Capacity at Different Voltages

MOG - S1

Rating	Ie (A)	AC240V	AC415V	AC460V	AC500V	AC690V
		AC230V	AC400V	AC440V		AC600V
Icu (A)						
0016	0.1 - 0.16	100	100	100	100	100
0025	0.16 - 0.25	100	100	100	100	100
0040	0.25 - 0.4	100	100	100	100	100
0063	0.4 - 0.63	100	100	100	100	100
0100	0.63 - 1	100	100	100	100	100
0160	1 - 1.6	100	100	100	100	100
0250	1.6 - 2.5	100	100	100	100	3
0400	2.5 - 4	100	100	100	100	3
0630	4 - 6.3	100	100	50	50	3
1000	6.3 - 10	100	100	15	10	3
1300	9 - 13	100	50	10	6	3

MOG - H1

Rating	Ie (A)	AC240V	AC415V	AC460V	AC500V	AC690V
		AC230V	AC400V	AC440V		AC600V
Icu (A)						
0016	0.1 - 0.16	100	100	100	100	100
0025	0.16 - 0.25	100	100	100	100	100
0040	0.25 - 0.4	100	100	100	100	100
0063	0.4 - 0.63	100	100	100	100	100
0100	0.63 - 1	100	100	100	100	100
0160	1 - 1.6	100	100	100	100	100
0250	1.6 - 2.5	100	100	100	100	8
0400	2.5 - 4	100	100	100	100	8
0630	4 - 6.3	100	100	100	100	6
1000	6.3 - 10	100	100	50	50	6
1300	9 - 13	100	100	50	42	6
1600	11 - 16	100	50	35	10	4
2000	14 - 20	100	50	35	10	4
2500	19 - 25	100	50	35	10	4
3200	24 - 32	100	50	35	10	4

MOG - H1M

Rating	In (A)	AC240V	AC415V	AC460V	AC500V	AC690V
		AC230V	AC400V	AC440V		AC600V
Icu (A)						
0016	0.16	100	100	100	100	100
0025	0.25	100	100	100	100	100
0040	0.4	100	100	100	100	100
0063	0.63	100	100	100	100	100
0100	1	100	100	100	100	100
0160	1.6	100	100	100	100	100
0250	2.5	100	100	100	100	8
0400	4	100	100	100	100	8
0630	6.3	100	100	100	100	6
1000	10	100	100	50	50	6
1300	13	100	100	50	42	6
1600	16	100	50	35	10	4
2000	20	100	50	35	10	4
2500	25	100	50	35	10	4
3200	32	100	50	35	10	4

MOG - H2

Rating	Ie (A)	AC240V	AC415V	AC460V	AC500V	AC690V
		AC230V	AC400V	AC440V		AC600V
Icu (A)						
3200	24 - 32	100	50	35	10	5
4000	28 - 40	100	50	35	10	5
5000	35 - 50	100	50	35	10	5
6300	45 - 63	100	50	35	10	5

MOG - H2M

Rating	In (A)	AC240V	AC415V	AC460V	AC500V	AC690V
		AC230V	AC400V	AC440V		AC600V
Icu (A)						
3200	32	100	50	35	10	5
4000	40	100	50	35	10	5
5000	50	100	50	35	10	5
6300	63	100	50	35	10	5

Ordering Information

Thermal & Magnetic Trip - Rocker Type

Frame size (mm)	Rating (A)	Motor Rating at 415V, 50Hz (kW)	Type Designation	Thermal Release Range (A)	Cat. Nos.	Breaking Capacity
45mm	0.16A	-	MOG - S1	0.1 - 0.16A	ST418890000	100kA
	0.25A	-		0.16 - 0.25A	ST418900000	
	0.4A	0.09		0.25 - 0.4A	ST418910000	
	0.63A	0.12		0.4 - 0.63A	ST418920000	
	1.0A	0.25		0.63 - 1.0A	ST418930000	
	1.6A	0.55		1.0 - 1.6A	ST418940000	
	2.5A	0.75		1.6 - 2.5A	ST418950000	
	4.A	1.50		2.5 - 4A	ST418960000	
	6.3A	2.20		4.0 - 6.3A	ST418970000	
	10.0A	4.00		6.3 - 10.0A	ST418980000	
	13.0A	5.40		9.0 - 13.0A	ST418990000	50kA

Thermal & Magnetic Trip - Rotary Type

Frame size (mm)	Rating (A)	Motor Rating at 415V, 50Hz (kW)	Type Designation	Thermal Release Range (A)	Cat. Nos.	Breaking Capacity
45mm	0.16A	-	MOG - H1	0.1 - 0.16A	ST419040000	100kA
	0.25A	-		0.16 - 0.25A	ST419050000	
	0.4A	0.09		0.25 - 0.4A	ST419060000	
	0.63A	0.12		0.4 - 0.63A	ST419070000	
	1.0A	0.25		0.63 - 1.0A	ST419080000	
	1.6A	0.55		1.0 - 1.6A	ST419090000	
	2.5A	0.75		1.6 - 2.5A	ST419100000	
	4.0A	1.50		2.5 - 4.0A	ST419110000	
	6.3A	2.20		4.0 - 6.3A	ST419120000	
	10.0A	4.00		6.3 - 10.0A	ST419130000	
	13.0A	5.40		9.0 - 13.0A	ST419140000	
	16.0A	7.50		11.0 - 16.0A	ST419150000	50kA
	20.0A	9.00		14.0 - 20.0A	ST419160000	
	25.0A	12.50		19.0 - 25.0A	ST419170000	
	32.0A	15.00		24.0 - 32.0A	ST419180000	
55mm	32.0A	15.00	MOG - H2	24.0 - 32.0A	ST419190000	
	40.0A	20.00		28.0 - 40.0A	ST419200000	
	50.0A	25.00		35.0 - 50.0A	ST419210000	
	63.0A	34.00		45.0 - 63.0A	ST419220000	

Instantaneous Trip - Rotary Type

Frame size (mm)	Rating (A)	Motor Rating at 415V, 50Hz (kW)	Type Designation	Thermal Release Range (A)	Cat. Nos.	Breaking Capacity
45mm	0.16	-	MOG - H1M	-	ST419230000	100kA
	0.25A	-		-	ST419240000	
	0.4A	0.09		-	ST419250000	
	0.63A	0.12		-	ST419260000	
	1.0A	0.25		-	ST419270000	
	1.6A	0.55		-	ST419280000	
	2.5A	0.75		-	ST419290000	
	4.0A	1.50		-	ST419300000	
	6.3A	2.20		-	ST419310000	
	10.0A	4.00		-	ST419320000	
	13.0A	5.40		-	ST419330000	
	16.0A	7.50		-	ST419340000	50kA
	20.0A	9.00		-	ST419350000	
	25.0A	12.50		-	ST419360000	
	32.0A	15.00		-	ST419370000	
55mm	32.0A	15.00	MOG - H2M	-	ST419380000	
	40.0A	20.00		-	ST419390000	
	50.0A	25.00		-	ST419400000	
	63.0A	34.00		-	ST419410000	

Accessories

Features

- All accessories can be used with MOG S1 (45mm wide), MOG H1 (45mm wide) and MOG H2 (55mm wide) frames
- Shunt trip and undervoltage trip devices are available in a wide range of operating voltages
- IP20 terminal cover prevents accidental contact to electrically charged parts

Auxiliary contact blocks : MOG-AXF, MOG-AXL

These blocks are linked to the ON/OFF operation of the MPCB. Up to two contact blocks can be mounted to the right/left front and up to two contact blocks can be mounted to the left side.



Alarm contact blocks : MOG-TAF

This block operates when the MPCB trips due to overload, phase-loss, or short-circuit. It is not linked to the ON/OFF operation of the MPCB.

Note : Operation can be checked with the test trip function.



Auxiliary and alarm contact blocks : MOG-ATL

- This contact block combines auxiliary contact and alarm contact that operate in the event of an overload, phase loss, or short-circuit. Alarm contact is not linked to the ON/OFF operation of the MPCB
- An alarm is displayed in the contact block's indicator when the alarm contact operates

Note : Operation can be checked with the test trip function.



Short-circuit alarm contact block : MOG-SAL

- The contacts operate only when the MPCB has tripped due to a short-circuit
- When these contacts operate, the blue reset button extends out, and a trip indication is displayed
- The power to the MPCB can be turned ON after pressing the reset button

Note : Operation can not be checked with the test trip function. Be sure to press the reset button before mounting to the MPCB.



Shunt trip devices : MOG-ST

This device is used to remotely trip the MPCB.

Notes:

- This device cannot be used together with an undervoltage trip device
- When the MPCB trips with the shunt trip device, press the reset button before turning ON the power



Accessories

Undervoltage trip devices : MOG-UV

This device automatically trips the MPCB when the control circuit voltage drops below the specified value.

Notes:

- This device cannot be used together with a shunt trip device
- When the MPCB has been tripped with the undervoltage trip device, press the reset button before turning ON the power



External operating handles : MOG-EH

- To operate the MPCB without opening the panel door
- Equipped with an interlock mechanism that prevents someone from opening the panel door when the MPCB is in the ON state
- The shaft can be cut to match the distance between the MPCB and the panel door
- Door interlock function
- OFF lock function

Note: Padlocks not included.

- Release screw allows the door to be opened with the handle in the ON position
- IP54 enclosure



Ratings of accessories

Accessory type		Auxiliary contact block/front	Auxiliary contact block/side	Alarm contact block	Aux. and alarm contact block	Short-circuit alarm contact block
Part number		MOG-AXF	MOG-AXL	MOG-TAF	MOG-ATL	MOG-SAL
Standard		IEC 60947-5-1				
Rated operational current (A)	48V AC AC-15	5	6	5	6	6
	125V AC	3	4	3	4	4
	230V AC	1.5	4	1.5	4	4
	400V AC	-	2.2	-	2.2	2.2
	500V AC	-	1.5	-	1.5	1.5
	690V AC	-	0.6	-	0.6	0.6
	48V DC DC-13	1.38	5	1.38	5	5
	110V DC	0.55	1.3	0.55	1.3	1.3
220V DC		0.27	0.5	0.27	0.5	0.5
Min. voltage and current		17V, 5mA				

Accessory type		Shunt trip device MOG-ST	Undervoltage device MOG-UV
Standard		IEC 60947-1	
Rated insulation voltage (V AC)		690	
No. of ON-OFF operations		5000	
Operating time (ms)		20	
Power consumption	Inrush (VA/W)	21/12	
	Sealed (VA/W)	8/1.2	
Voltage range	Tripping voltage (V)	0.7 to 1.1Ue	0.35 to 0.7Ue
	Closing voltage (V)	-	0.85 to 1.1Ue
Time rating of coil (s)		AC: Continuous DC: 5	AC: Continuous

Note: Ue: Rated Voltage

Selection Chart

Fuseless Protection for DOL Starter Feeders with MPCB MOG-H1M/H2M Type '2' Co-ordination, I_q=50 kA at 415V, 3Ø, 50 Hz as per Standards : IEC 60947-4-1, IS 13947 (Part 4/Sec. 1), EN 60947-4-1

- The selection is valid only for complete L&T combinations i.e. MPCB + Relay + Contactor
- In any case if this combination is changed to accommodate another brand / rating of MPCB etc. it shall be the responsibility of the person making such a change to assure type 2 performance
- Selection is for normal starting conditions with starting time

According to Type '2' Co-ordination, I_q=50kA at 415V, 3Ø, 50Hz

Sr. No.	Motor Rating: 3Ø, 415V, 50Hz			Contactor	Overload Relay		MPCB (Only Magnetic)	
	hp	kW	I _L	Type	Type	Range (A)	Type	Rating I _M (A)
1	0.125	0.09	0.40	MO 9	MO - RTO1	0.3 - 0.45	MOG - H1M	0.63
2	0.16	0.12	0.45	MO 9	MO - RTO1	0.3 - 0.45	MOG - H1M	0.63
3	0.2	0.15	0.57	MO 9	MO - RTO1	0.45 - 0.67	MOG - H1M	1
4	0.25	0.19	0.75	MO 9	MO - RTO1	0.67 - 1.0	MOG - H1M	1
5	0.33	0.25	0.90	MO 9	MO - RTO1	0.67 - 1.0	MOG - H1M	1.6
6	0.5	0.37	1.20	MO 9	MO - RTO1	1.0 - 1.5	MOG - H1M	1.6
7	0.75	0.55	1.60	MO 9	MO - RTO1	1.2 - 2.1	MOG - H1M	2.5
8	1	0.75	2.10	MO 9	MO - RTO1	1.8 - 2.7	MOG - H1M	2.5
9	1.5	1.10	2.70	MO 9	MO - RTO1	2.4 - 3.6	MOG - H1M	4
10	1.75	1.30	3.00	MO 9	MO - RTO1	2.4 - 3.6	MOG - H1M	4
11	2	1.50	3.50	MO 9	MO - RTO1	3.5 - 5.0	MOG - H1M	6.3
12	2.5	1.80	4.80	MO 9	MO - RTO1	3.5 - 5.0	MOG - H1M	6.3
13	3	2.25	5.00	MO 9	MO - RTO1	4.0 - 6.0	MOG - H1M	6.3
14	4	3.00	6.40	MO 9	MO - RTO1	6.3 - 9.0	MOG - H1M	10
15	5	3.70	7.90	MO 9	MO - RTO1	6.3 - 9.0	MOG - H1M	10
16	5.5	4.00	8.50	MO 9	MO - RTO1	6.3 - 9.0	MOG - H1M	10
17	6	4.50	9.00	MO 12	MO - RTO1	8.5 - 12.5	MOG - H1M	13
18	7.5	5.50	11.20	MO 12	MO - RTO1	8.5 - 12.5	MOG - H1M	16
19	10	7.50	14.80	MO 18	MO - RTO1	12.5 - 18	MOG - H1M	20
20	12.5	9.30	19.00	MO 25	MO - RTO1	17 - 24	MOG - H1M	25
21	15	11.00	22.00	MO 25	MO - RTO1	17 - 24	MOG - H1M	32
22	17.5	13.00	24.00	MO 32	MO - RTO1	22- 32	MOG - H1M	32
23	20	15.00	29.00	MO 32	MO - RTO1	22 - 32	MOG - H2M	40
24	25	18.60	35.00	MO 40	MO - RTO1	30 - 40	MOG - H2M	50
25	30	22.50	40.00	MO 40	MO - RTO1	35 - 45	MOG - H2M	50
26	35	26.00	47.00	MO 50	MN 5	30 - 50	MOG - H2M	63

Selection Chart

Fuseless Protection for DOL Starter Feeders with MPCB
MOG-S1/H1/H2 Type '2' Co-ordination, I_q=50 kA at 415V, 3Ø, 50 Hz as per
Standards : IEC 60947-4-1, IS 13947 (Part 4/Sec. 1), EN 60947-4-1

Sr. No.	Motor Rating: 3Ø, 415V, 50Hz			Contactor	Overload Relay		MPCB (Only Magnetic)	
	hp	kW	I _L	Type	Type	Range (A)	Type	Rating I _M (A)
1	0.125	0.09	0.40	MO 9	-	-	MOG - S1 / MOG - H1	0.4 - 0.63
2	0.16	0.12	0.45	MO 9	-	-	MOG - S1 / MOG - H1	0.4 - 0.63
3	0.2	0.15	0.57	MO 9	-	-	MOG - S1 / MOG - H1	0.63 - 1
4	0.25	0.19	0.75	MO 9	-	-	MOG - S1 / MOG - H1	0.63 - 1
5	0.33	0.25	0.90	MO 9	-	-	MOG - S1 / MOG - H1	1 - 1.6
6	0.5	0.37	1.20	MO 9	-	-	MOG - S1 / MOG - H1	1 - 1.6
7	0.75	0.55	1.60	MO 9	-	-	MOG - S1 / MOG - H1	1.6 - 2.5
8	1	0.75	2.10	MO 9	-	-	MOG - S1 / MOG - H1	1.6 - 2.5
9	1.5	1.10	2.70	MO 9	-	-	MOG - S1 / MOG - H1	2.5 - 4
10	1.75	1.30	3.00	MO 9	-	-	MOG - S1 / MOG - H1	2.5 - 4
12	2.5	1.80	4.80	MO 9	-	-	MOG - S1 / MOG - H1	4 - 6.3
13	3	2.25	5.00	MO 9	-	-	MOG - S1 / MOG - H1	4 - 6.3
14	4	3.00	6.40	MO 9	-	-	MOG - S1 / MOG - H1	6.3 - 10
15	5	3.70	7.90	MO 9	-	-	MOG - S1 / MOG - H1	6.3 - 10
16	5.5	4.00	8.50	MO 9	-	-	MOG - S1 / MOG - H1	16.3 - 10
17	6	4.50	9.00	MO 12	-	-	MOG - S1 / MOG - H1	9 - 13
18	7.5	5.50	11.20	MO 12	-	-	MOG - H1	11 - 16
19	10	7.50	14.80	MO 18	-	-	MOG - H1	14 - 20
20	12.5	9.30	19.00	MO 25	-	-	MOG - H1	19 - 25
22	17.5	13.00	24.00	MO 32	-	-	MOG - H1	24 - 32
23	20	15.00	29.00	MO 32	-	-	MOG - H2	28 - 40
24	25	18.60	35.00	MO 40	-	-	MOG - H2	30 - 50
25	30	22.50	40.00	MO 40	-	-	MOG - H2	35 - 50
26	35	26.00	47.00	MO 50	-	-	MOG - H2	40 - 63



Selection Chart

Fuseless Protection for DOL Starter Feeders with MPCB
MOG-S1/H1/H2 Type '2' Co-ordination, Iq=50 kA at 415V, 3Ø, 50 Hz as per
Standards : IEC 60947-4-1, IS 13947 (Part 4/Sec. 1), EN 60947-4-1

Sr. No.	Motor Rating: 3Ø, 415V, 50Hz			Overload Relay		Contactor	MPCB	
	hp	kW	FLC, In (A)	Type	Range (A)		Type	Rating
1	0.125	0.09	0.4	-	-	MNX 9	MOG - S1 / MOG - H1	0.25 - 0.4
2	0.16	0.12	0.45	-	-	MNX 9	MOG - S1 / MOG - H1	0.4 - 0.63
3	0.2	0.15	0.57	-	-	MNX 9	MOG - S1 / MOG - H1	0.4 - 0.63
4	0.25	0.19	0.75	-	-	MNX 9	MOG - S1 / MOG - H1	0.63 - 1
5	0.33	0.25	0.9	-	-	MNX 9	MOG - S1 / MOG - H1	0.63 - 1
6	0.5	0.37	1.2	-	-	MNX 9	MOG - S1 / MOG - H1	1 - 1.6
7	0.75	0.55	1.6	-	-	MNX 9	MOG - S1 / MOG - H1	1 - 1.6
8	1	0.75	2.1	-	-	MNX 12	MOG - S1 / MOG - H1	1.6 - 2.5
9	1.5	1.1	2.7	-	-	MNX 12	MOG - S1 / MOG - H1	2.5 - 4
10	1.75	1.3	3	-	-	MNX 12	MOG - S1 / MOG - H1	2.5 - 4
11	2	1.5	3.5	-	-	MNX 12	MOG - S1 / MOG - H1	2.5 - 4
12	2.5	1.8	4.8	-	-	MNX 12	MOG - S1 / MOG - H1	4 - 6.3
13	3	2.25	5	-	-	MNX 12	MOG - S1 / MOG - H1	4 - 6.3
14	4	3	6.4	-	-	MNX 12	MOG - S1 / MOG - H1	6.3 - 10
15	5	3.7	7.9	-	-	MNX 12	MOG - S1 / MOG - H1	6.3 - 10
16	6	4.5	9	-	-	MNX 12	MOG - S1 / MOG - H1	6.3 - 10
17	7.5	5.5	11.2	-	-	MNX 12	MOG - S1 / MOG - H1	9 - 13
18	10	7.5	14.8	-	-	MNX 18	MOG - H1	11 - 16
19	12.5	9.3	19	-	-	MNX 25	MOG - H1	14 - 20
20	15	11	22	-	-	MNX 25	MOG - H1	19 - 25
21	17.5	13	24	-	-	MNX 32	MOG - H1	19 - 25
22	20	15	29	-	-	MNX 40	MOG - H1	24 - 32
23	25	18.6	35	-	-	MNX 40	MOG - H2	28 - 40
24	30	22.5	40	-	-	MNX 45	MOG - H2	28 - 40
25	35	26	47	-	-	MNX 70	MOG - H2	35 - 50
26	40	30	55	-	-	MNX 80	MOG - H2	45 - 63
27	45	33.5	60	-	-	MNX 80	MOG-H2	45 - 63

Selection Chart

Fuseless Protection for DOL Starter Feeders with MPCB
Type MOG-H1M/H2M Type '2' Co-ordination, Iq=50 kA at 415V, 3Ø, 50 Hz as per
Standards : IEC 60947-4-1, IS 13947 (Part 4/Sec. 1), EN 60947-4-1

Sr. No.	Motor Rating, 415V, 3 ph.		FLC (A)	Relay		Contactor	MPCB (Only Magnetic)	
	hp	kW		Type	Range (A)		Type	Rating
1	0.125	0.09	0.4	MN2	0.3 - 0.5	MNX 12	MOG - H1M	0.4
2	0.16	0.12	0.45	MN2	0.45 - 0.75	MNX 12	MOG - H1M	0.63
3	0.2	0.15	0.57	MN2	0.45 - 0.75	MNX 12	MOG - H1M	0.63
4	0.25	0.19	0.7	MN2	0.6 - 1	MNX 12	MOG - H1M	1
5	0.33	0.25	0.9	MN2	0.6 - 1	MNX 12	MOG - H1M	1
6	0.5	0.37	1.2	MN2	0.9 - 1.5	MNX 12	MOG - H1M	1.6
7	0.75	0.55	1.6	MN2	1.4 - 2.3	MNX 12	MOG - H1M	1.6
8	1	0.75	2.1	MN2	1.4 - 2.3	MNX 12	MOG - H1M	2.5
9	1.5	1.1	2.7	MN2	2.0 - 3.3	MNX 12	MOG - H1M	4
10	1.75	1.3	3	MN2	2.0 - 3.3	MNX 12	MOG - H1M	4
11	2	1.5	3.8	MN2	3.0 - 5.0	MNX 12	MOG - H1M	4
12	2.5	1.8	4.8	MN2	4.5 - 7.5	MNX 12	MOG - H1M	6.3
13	3	2.25	5	MN2	4.5 - 7.5	MNX 12	MOG - H1M	6.3
14	4	3	6.2	MN2	4.5 - 7.5	MNX 12	MOG - H1M	10
15	5	3.7	7.9	MN2	6 - 10	MNX 12	MOG - H1M	10
16	6	4.5	9	MN2	6 - 10	MNX 12	MOG - H1M	10
17	7.5	5.5	11.4	MN2	9 - 15	MNX 32	MOG - H1M	13
18	10	7.5	15.4	MN2	14 - 23	MNX 32	MOG - H1M	16
19	12.5	9.3	19.5	MN2	14 - 23	MNX 32	MOG - H1M	20
20	15	11	23	MN2	20 - 33	MNX 32	MOG - H1M	25
21	17.5	13	24	MN2	20 - 33	MNX 32	MOG - H1M	25
22	20	15	29	MN2	20 - 33	MNX 32	MOG - H1M	32
23	25	18.6	35	MN2	24 - 40	MNX 40	MOG - H2M	40
24	30	22.5	40	MN5	30 - 50	MNX 45	MOG - H2M	50
25	35	26	47	MN5	30 - 50	MNX 70	MOG - H2M	50
26	40	30	55	MN5	45 - 75	MNX 80	MOG - H2M	63
27	45	33.5	60	MN5	45 - 75	MNX 80	MOG - H2M	63

IT Characteristics

Type MOG - S1 (0.16A - 13A)

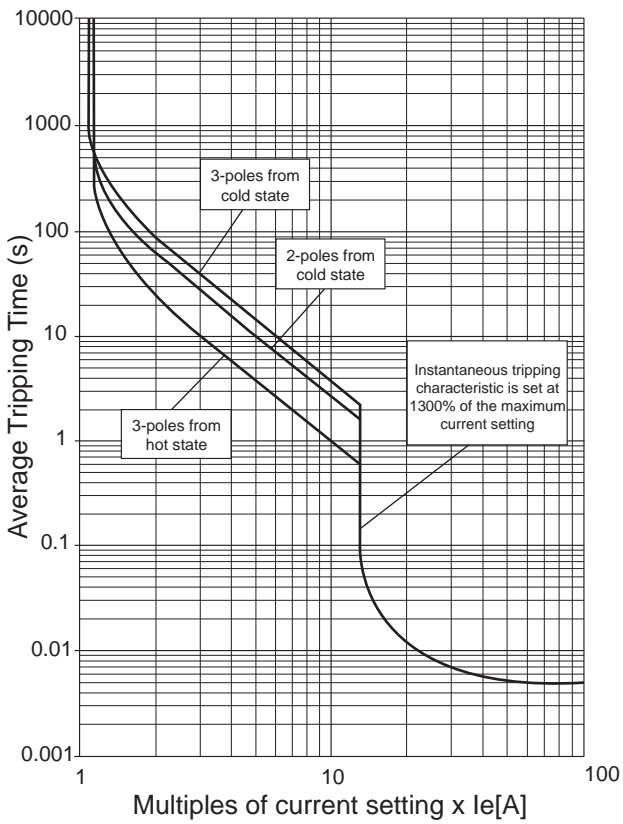

Type MOG - H1 (0.16A - 32A)

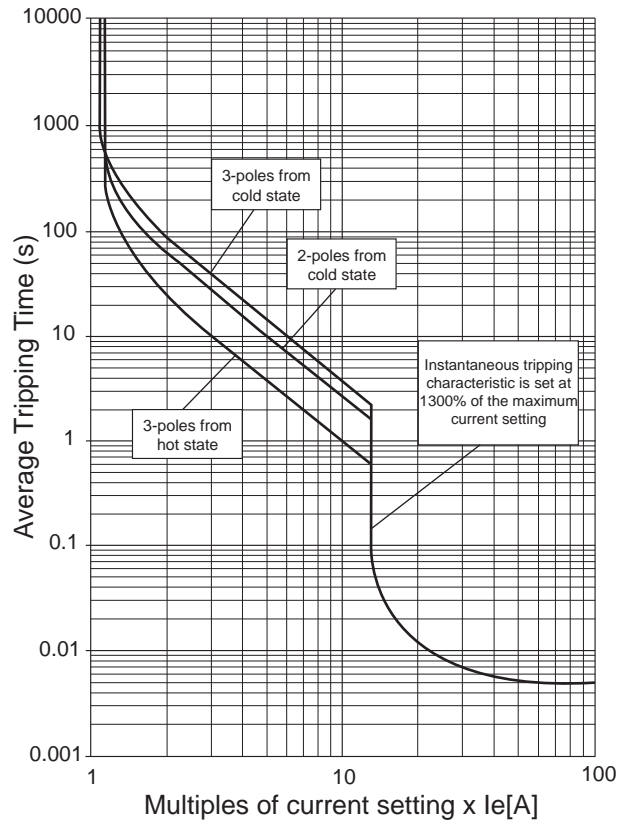

Type MOG - H2 (32A - 63A)

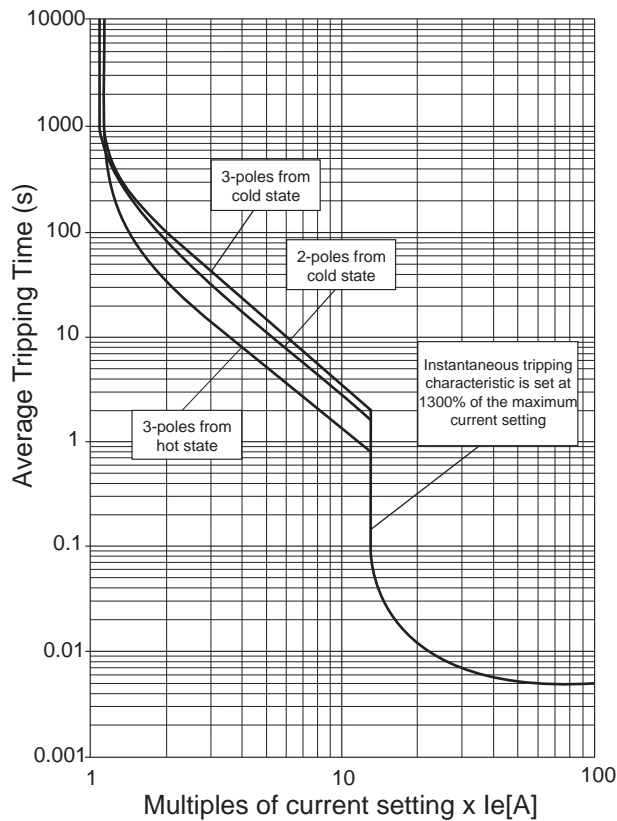

IT Characteristics

Type MOG - H1M (0.16A - 32A)

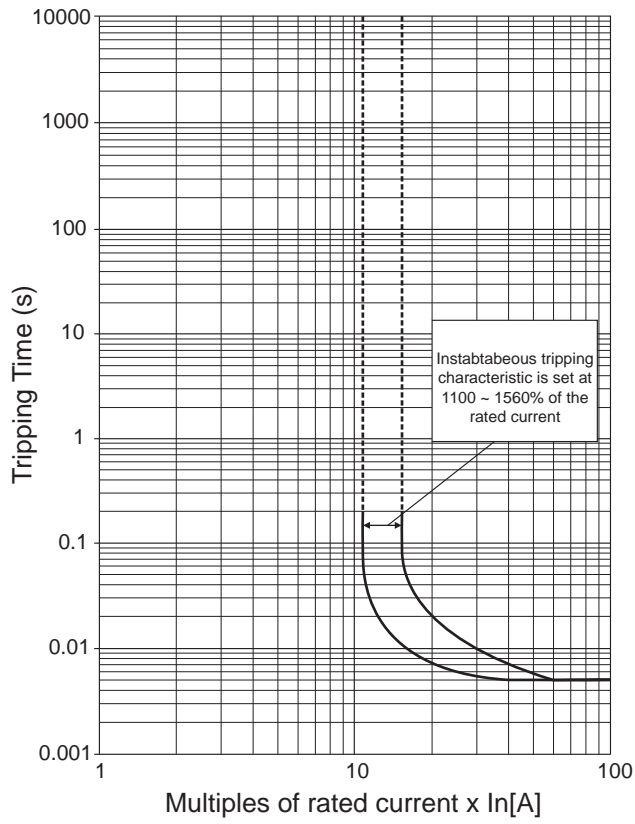

Type MOG - H2M (32A - 63A)

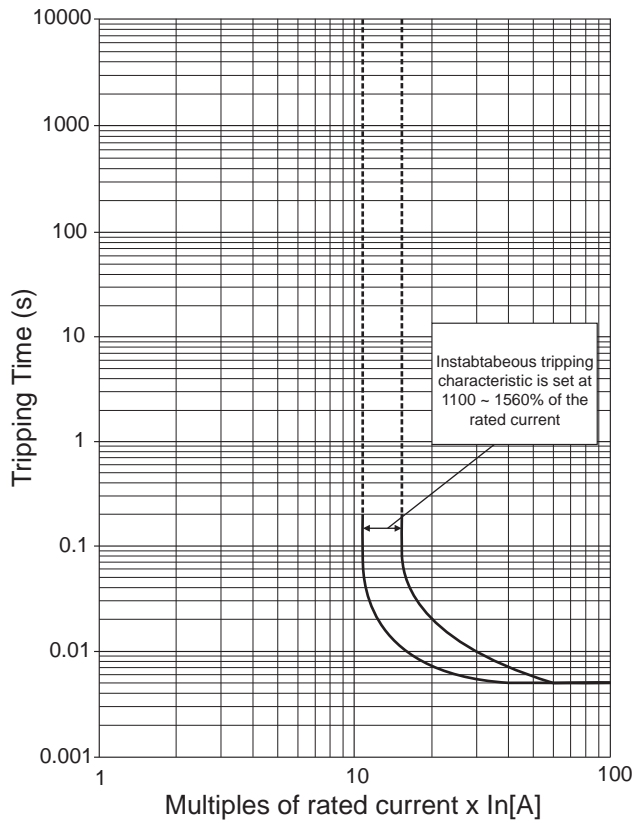

Overall Dimensions

Type MOG - S1 (0.16A - 13A)

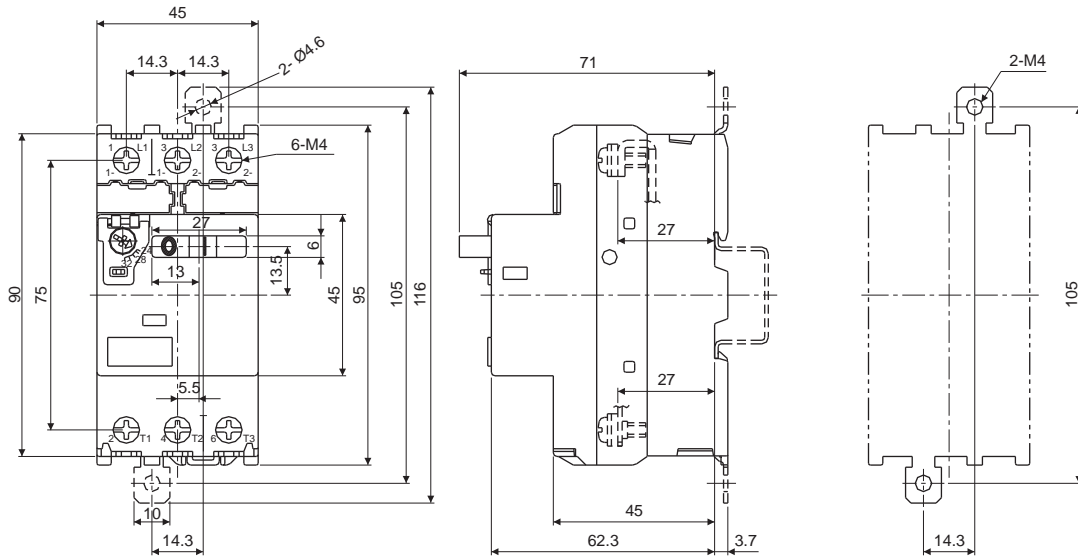

Type MOG - H1 & MOG - H1M (0.16A - 32A)

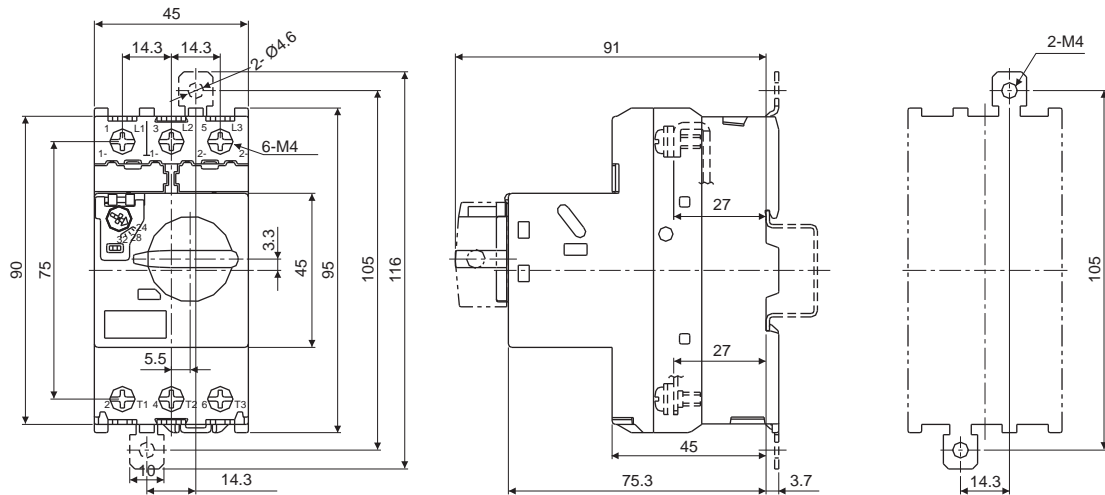

Type MOG - H2 & MOG - H2M (32A - 63A)

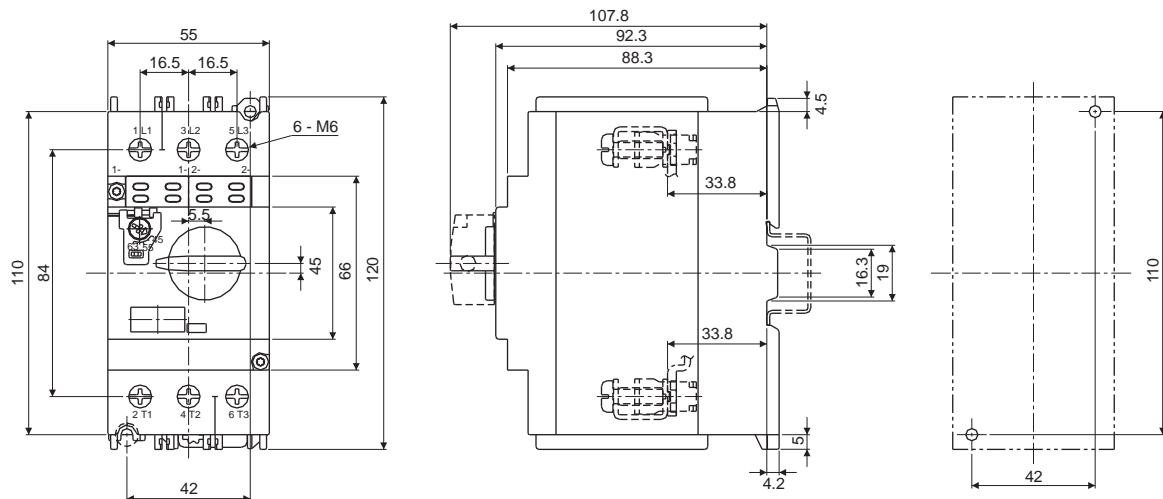

Overall Dimensions

Trip Alarm Contact Front 1NO

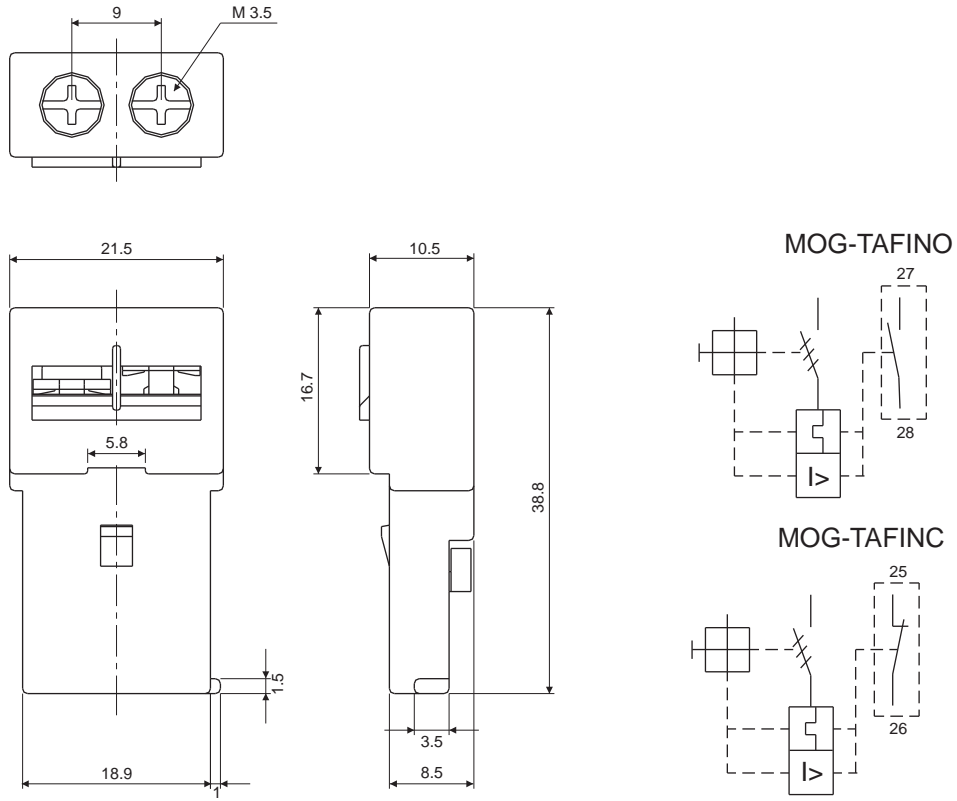

S / C Alarm Left 1NO + 1NC

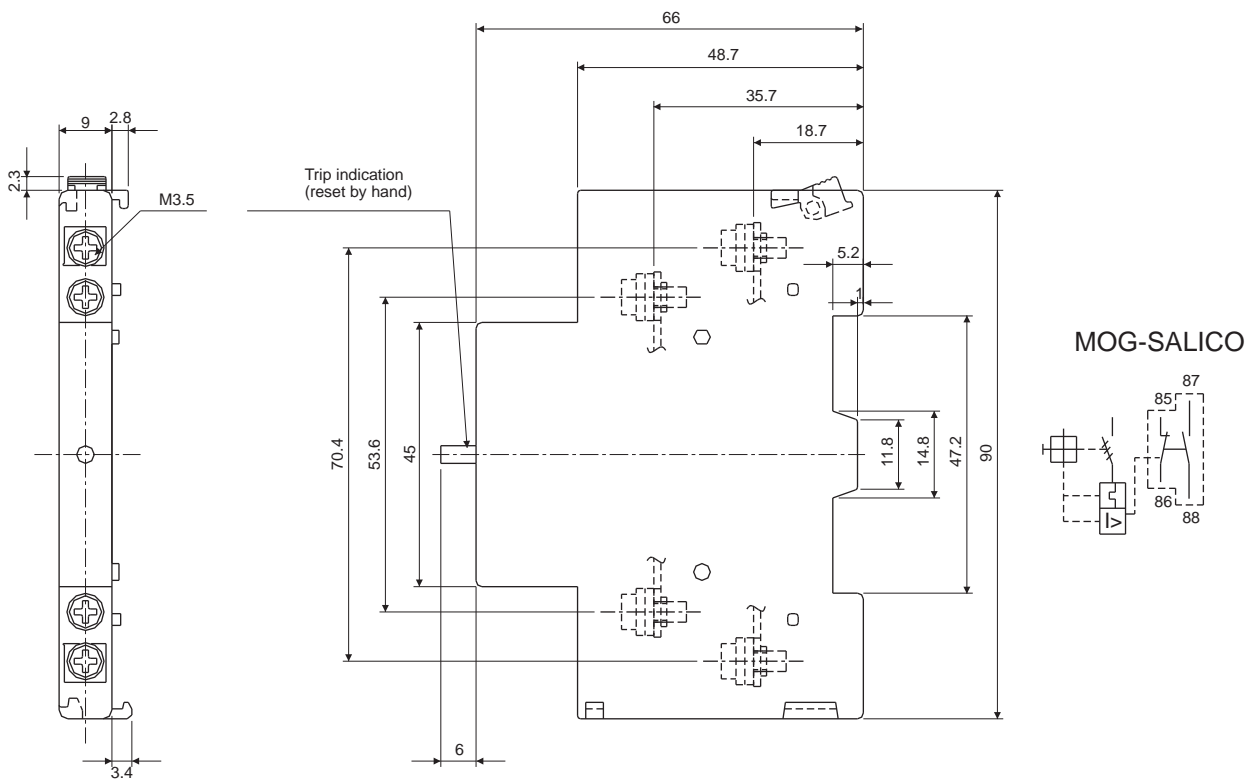

Overall Dimensions

Aux. Alarm Left 2NO

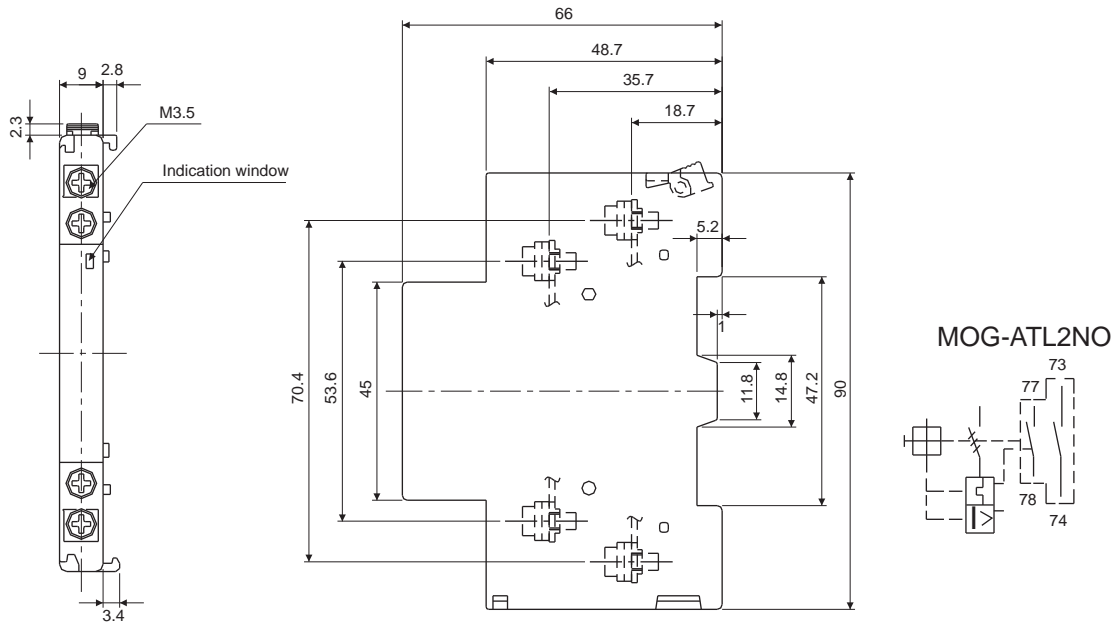

Aux. Contact Left 2NO

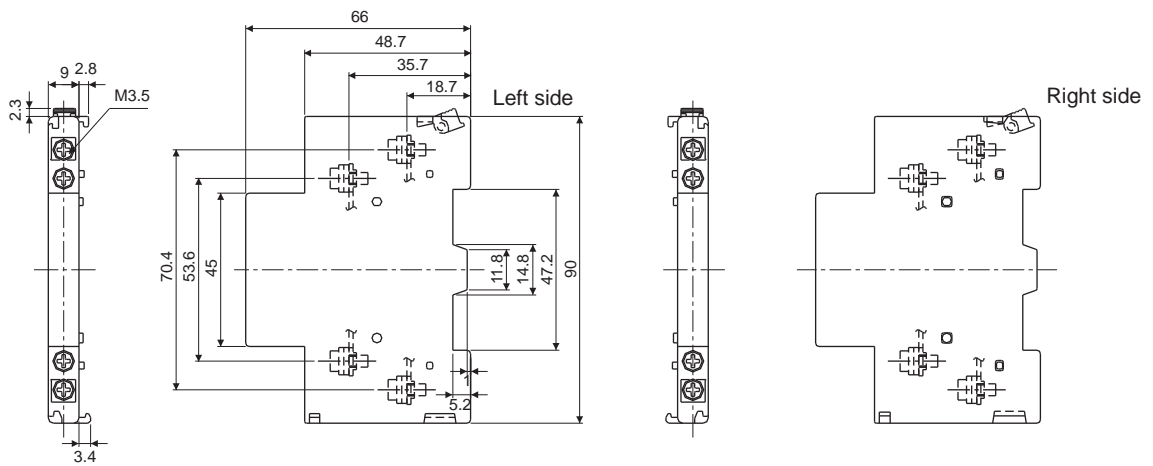

MOG-AXL2NO MOG-AXL1CO MOG-AXL2NC

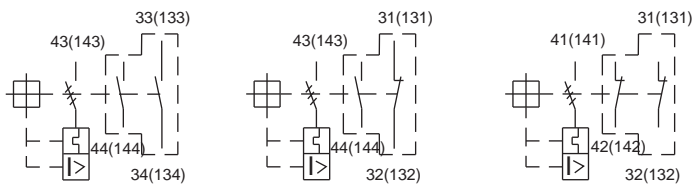

Overall Dimensions

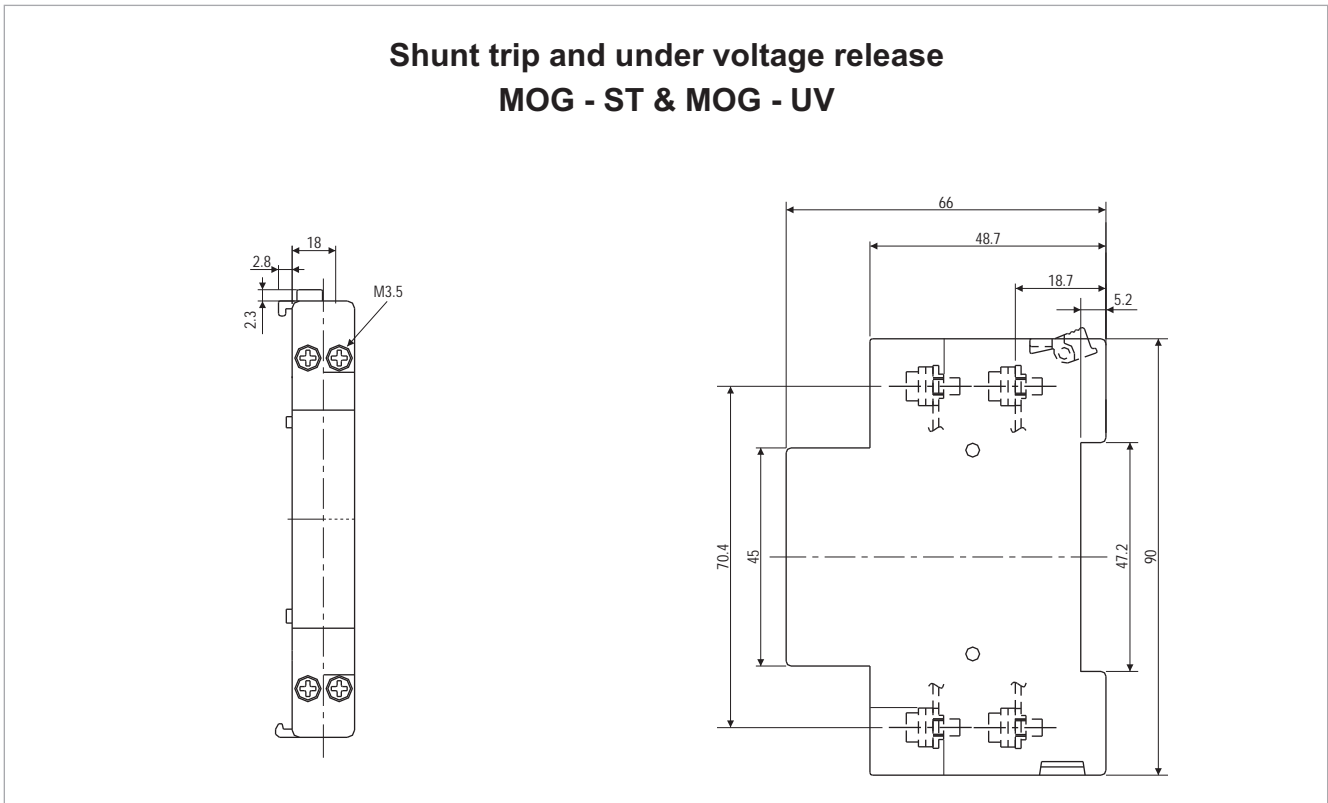

Accessories for MPCB

Cat. Nos.	Description	Model Numbers	Position	Terminal Marking	
				NO	NC
ST419420000	Auxiliary Contact Front mtg. 1NO	MOG-AXF 1NO	F (Slot 1 / Slot 2)	13, 14 (23, 24)	
ST419430000	Auxiliary Contact Front mtg. 1NC	MOG-AXF 1NC	F (Slot 1 / Slot 2)		11, 12 (21, 22)
ST419440000	Auxiliary Contact Left side mtg. 2NO	MOG-AXL 2NO	L	"33, 34 (133, 134) 43, 44 (143, 144)"	
ST419450000	Auxiliary Contact Left side mtg. 1NO + 1NC	MOG-AXL 1CO	L	43, 44 (143, 144)	31, 32 (131, 132)
ST419460000	Auxiliary Contact Left side mtg. 2NC	MOG-AXL 2NC	L		"31, 32 (131, 132) 41, 42 (141, 142)"
ST419470000	Trip Alarm Contact Front mtg. 1NO	MOG-TAF 1NO	F (Slot 2 only)	27, 28	
ST419480000	Trip Alarm Contact Front mtg. 1NC	MOG-TAF 1NC	F (Slot 2 only)		25, 26
ST419490000	Auxiliary + Alarm Left side mtg. 2NO	MOG-ATL 2NO	L	"73, 74 77, 78"	
ST419500000	Short circuit alarm Left side mtg. 1NO + 1NC	MOG-SAL 1CO	L	87, 88	85, 86
ST419510000	Shunt trip 24V DC	MOG-ST	R (one at a time)	C1, C2	
ST419520000	Shunt trip 110V, 50Hz	MOG-ST			
ST429520000	Shunt trip 230V, 50Hz	MOG-ST			
ST419530000	Under Voltage release, 110V, 50Hz	MOG-UV		D1, D2	
ST419540000	Under Voltage release, 415V, 50Hz	MOG-UV			

F - Front Mounting

L - LHS Mounting

R - RHS Mounting

Note:

1) On LHS any 2 accessories can be fitted (Alarm contact followed by Auxiliary contact)

- MOG-ATL 2NO + MOG-AXL 1CO
- MOG-SAL 1CO + MOG-AXL 1CO

2) On RHS only 1 accessory can be fitted (Shunt trip release or Undervoltage release)

3) Any 2 Front mounted accessories are possible at a time.

- Front mounted TAF to be fitted only in slot 2
- Front mounted auxiliary contact can be fitted in slot 1 / slot 2